



**MAGNETIC CURVES**

**AVE**

**A MEGADYNE GROUP CO.**



# AVE

**A MEGADYNE GROUP CO.**



## **TRANSMISIONES MECÁNICAS AVE CHAINS, MODULAR BELTS & CONVEIOR COMPONENTS**

---

Founded in 1953, AVE is now part of the Conveyor production business unit of Megadyne Group.

---

Over more than 50 years AVE has evolved to meet the needs of its customers. Today specializing in the development and manufacture of chains, belts, guides and components in stainless steel and new materials for high performance.

To provide and service companies in different sectors: Manufacturers of bottling and packaging equipment, Bottling, Breweries, cosmetics, cars, all those companies that require product transport facilities.

Present in major international markets.

AVE is the result of merging the design, manufacture and distribution getting the necessary synergies for over 50 years of activity and confidence of our customers, spread across 5 continents, result of an efficient and responsible.

AVE, design and manufacture quality products, We reasoned solutions, the best service possible, the tight and competitive price. Our greatest asset is our team composed of top professionals in different areas combining high technology, knowledge, strength and youth, with the order to remain one of the leading companies in the sector.

In AVE work with an orderly method based on knowledge and technology. Collecting the latest technology, computer environmental and energy efficiency.

COD.	Pag.	COD.	Pag.	COD.	Pag.
CM.0010.01.90	10	CM.0211.04.90	13	CM.B360.03.90	6
CM.0010.02.90	10	CM.0221.01.90	15	CM.B360.04.90	6
CM.0010.03.90	10	CM.0221.02.90	15	CM.B360.05.90	6
CM.0010.04.90	10	CM.0221.03.90	15	CM.B360.06.90	6
CM.0010.05.90	10	CM.0221.04.90	15	CM.B521.01.90	14
CM.0010.06.90	10	CM.0420.01.90	19	CM.B521.02.90	14
CM.0014.01.90	9	CM.0420.02.90	19	CM.B521.03.90	14
CM.0014.02.90	9	CM.0420.03.90	19	CM.B521.04.90	14
CM.0014.03.90	9	CM.0420.04.90	19	CM.B521.05.90	14
CM.0014.04.90	9	CM.0420.05.90	19	CM.B521.06.90	14
CM.0014.05.90	9	CM.0420.06.90	19	CM.B560.01.90	7
CM.0014.06.90	9	CM.0430.01.90	28	CM.B560.02.90	7
CM.0020.01.90	12	CM.0430.02.90	28	CM.B560.03.90	7
CM.0020.02.90	12	CM.0430.03.90	28	CM.B560.04.90	7
CM.0020.03.90	12	CM.0430.04.90	28	CM.B560.05.90	7
CM.0020.04.90	12	CM.0430.05.90	28	CM.B560.06.90	7
CM.0020.05.90	12	CM.0430.06.90	28	CM.P861.01.90	23
CM.0020.06.90	12	CM.0610.01.90	17	CM.P910.01.15	25
CM.0030.01.90	11	CM.0610.02.90	17	CM.P910.01.30	25
CM.0030.02.90	11	CM.0610.03.90	17	CM.P910.01.45	25
CM.0030.03.90	11	CM.0610.04.90	17	CM.P910.01.60	25
CM.0030.04.90	11	CM.0650.01.15	29	CM.P910.01.75	25
CM.0030.05.90	11	CM.0650.01.30	29	CM.P910.01.90	25
CM.0030.06.90	11	CM.0650.01.45	29	CM.P960.01.15	27
CM.0040.01.90	8	CM.0650.01.60	29	CM.P960.01.30	27
CM.0040.02.90	8	CM.0650.01.75	29	CM.P960.01.45	27
CM.0040.03.90	8	CM.0650.01.90	29	CM.P960.01.60	27
CM.0040.04.90	8	CM.0660.01.15	22	CM.P960.01.75	27
CM.0040.05.90	8	CM.0660.01.30	22	CM.P960.01.90	27
CM.0040.06.90	8	CM.0660.01.45	22		
CM.0051.01.15	18	CM.0660.01.60	22		
CM.0051.01.30	18	CM.0660.01.75	22		
CM.0051.01.45	18	CM.0660.01.90	22		
CM.0051.01.60	18	CM.0810.01.90	16		
CM.0051.01.75	18	CM.0810.02.90	16		
CM.0051.01.90	18	CM.0810.03.90	16		
CM.0053.01.15	20	CM.0810.04.90	16		
CM.0053.01.30	20	CM.0860.01.15	21		
CM.0053.01.45	20	CM.0860.01.30	21		
CM.0053.01.60	20	CM.0860.01.45	21		
CM.0053.01.75	20	CM.0860.01.60	21		
CM.0053.01.90	20	CM.0860.01.75	21		
CM.0060.01.90	5	CM.0860.01.90	21		
CM.0060.02.90	5	CM.0910.01.15	24		
CM.0060.03.90	5	CM.0910.01.30	24		
CM.0060.04.90	5	CM.0910.01.45	24		
CM.0060.05.90	5	CM.0910.01.60	24		
CM.0060.06.90	5	CM.0910.01.75	24		
CM.0070.01.90	4	CM.0910.01.90	24		
CM.0070.02.90	4	CM.0960.01.15	26		
CM.0070.03.90	4	CM.0960.01.30	26		
CM.0070.04.90	4	CM.0960.01.45	26		
CM.0070.05.90	4	CM.0960.01.60	26		
CM.0070.06.90	4	CM.0960.01.75	26		
CM.0211.01.90	13	CM.0960.01.90	26		
CM.0211.02.90	13	CM.B360.01.90	6		
CM.0211.03.90	13	CM.B360.02.90	6		

UBICACIÓN POR RADIO  
LOCATION BY RADIUS  
EMPLACEMENT PAR RAYON  
STANDORT NACH RADIUS



**500**  
Pag.  
4 - 14



**610**  
Pag.  
15 - 17



**680**  
Pag.  
18



**750**  
Pag.  
19



**860**  
Pag.  
20 - 27



**1000**  
Pag.  
28 - 29



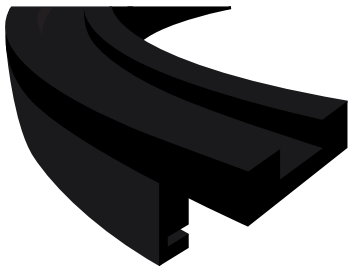

**STD**

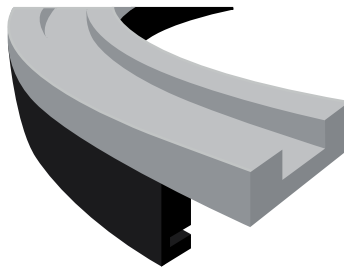

**WR**

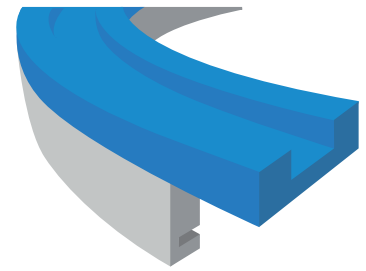

**WXB**

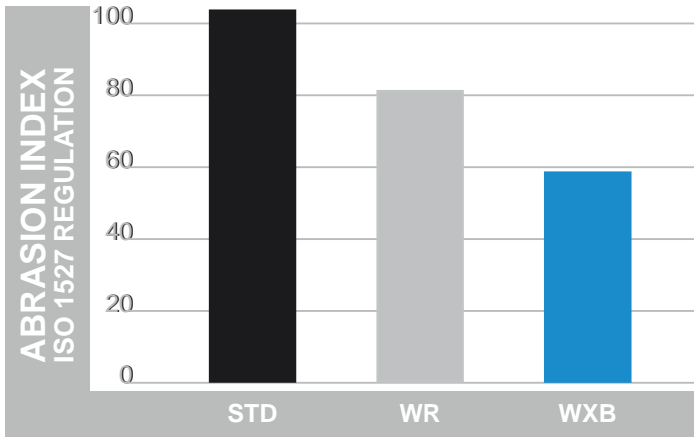

**ALTA DURABILIDAD / HIGH DURABILITY / HAUTE DURABILITÉ / HOHE HALTBARKEIT**

El material **WXB** muestra los mejores resultados. Bajo coeficiente de abrasión (reduciendo el desgaste, -20%), y por tanto mayor vida útil.

The **WXB** material shows the best results. Low coefficient of friction (reducing wear, -20%), and therefore longer lifespan.

Le matériau **WXB** montre les meilleurs résultats. Faible coefficient d'abrasion (réduction de l'usure, -20%), donc durée de vie plus longue.

Das **WXB**-Material zeigt die besten Ergebnisse. Niedriger Abriebkoeffizient (Verringerung des Verschleißes, -20%) und somit längere Lebensdauer.

**FÁCIL MANTENIMIENTO / EASY MAINTENANCE / MAINTENANCE FACILE / EINFACHE WARTUNG**

Mantenimiento rápido y sencillo que permite reducir el tiempo de paro de producción.

The interventions are quick and simple allowing to reduce production downtime.

Maintenance rapide et simple qui réduit les temps d'arrêt de production.

Schnelle und einfache Wartung, die Produktionsausfallzeiten reduziert



**COEFICIENTE DE FRICCIÓN MUY BAJO/ VERY LOW FRICTION COEFFICIENT / COEFFICIENT DE FRICTION TRÈS FAIBLE / SEHR NIEDRIGER REIBUNGSKOEFFIZIENT**

El **WXB** proporciona excelentes resultados en aplicaciones de alta velocidad, no lubricantes y abrasivas.

**WXB** provides excellent results in high-speed, non-lubricating, and abrasive applications.

Le **WXB** fournit d'excellents résultats dans des applications à grande vitesse, non lubrifiantes et abrasives.

Das **WXB** liefert hervorragende Ergebnisse in Hochgeschwindigkeitsanwendungen, nicht schmierenden und abrasiven Anwendungen.

MATERIAL	APPLICATIONS			
	Stainless steel chains. Clean and lubricated	Lubricated and abrasion-resistant thermoplastic chains	Stainless steel chains and thermoplastics with low dry speed	High speed drying thermoplastic chains
<b>STD</b> - UHMW-PE	✓			
<b>WR</b> - WEAR RESISTANT		✓	✓	
<b>WXB</b> - HIGH PERFORMANCE			✓	✓

Nota: Si el rango estándar de este catálogo no cumple con las necesidades de su equipo, podemos fabricar otras curvas personalizadas.

Note: If the standard range in this catalog does not meet the needs of your equipment, we can manufacture other custom curves.

Remarque: Si la gamme standard de ce catalogue ne répond pas aux besoins de votre équipement, nous pouvons fabriquer d'autres courbes personnalisées.

Hinweis: Wenn der Standardbereich dieses Katalogs nicht den Anforderungen Ihrer Ausrüstung entspricht, können wir andere benutzerdefinierte Kurven erstellen.

MODELO CM.0070 / MODEL CM.0070 / MODÈLE CM.0070 / MODELL CM.0070

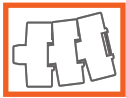

879 M - 880 M - 881 M - 881 MX

**M** SPECIAL UHMW-PE

Según tabla  
 According to table  
 Selon le tableau  
 Laut Tabelle

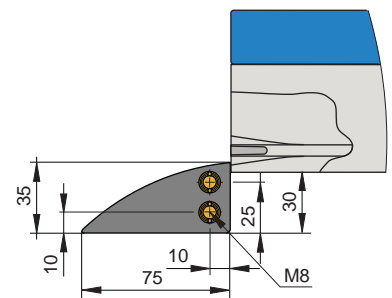
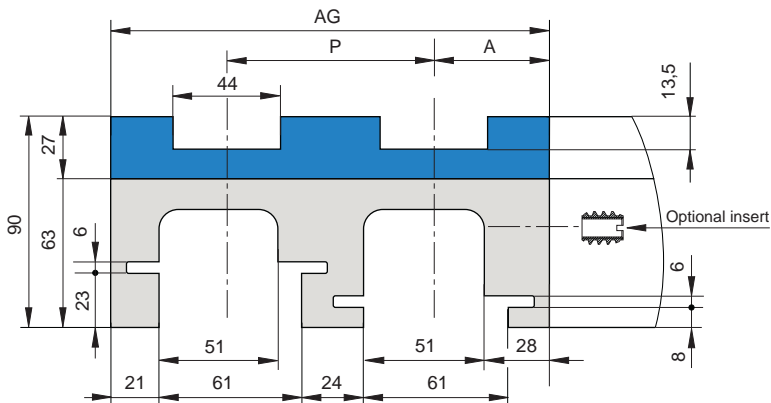
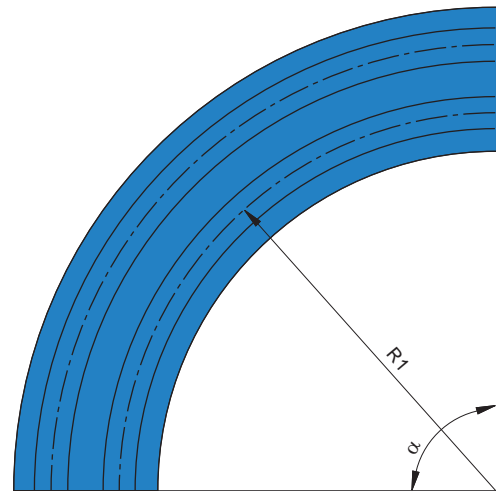
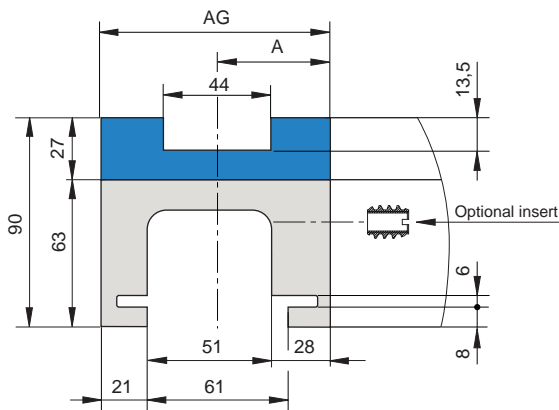
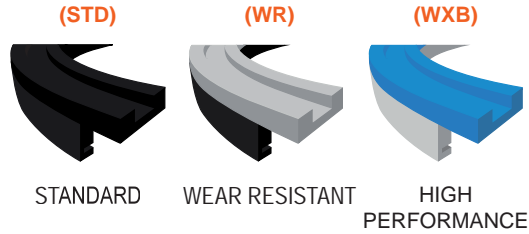
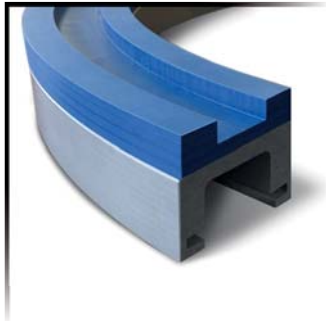

K = 82,5 - K = 83,8

P = 85mm

COD.	*MAT.	R1	A	AG	α	VIAS
CM.0070.01.90.STD	STD	500	50	100	90	1
CM.0070.02.90.STD		500	50	185	90	2
CM.0070.03.90.STD		500	50	270	90	3
CM.0070.04.90.STD		500	50	355	90	4
CM.0070.05.90.STD		500	50	440	90	5
CM.0070.06.90.STD		500	50	525	90	6

\* OTHER MATERIALS  
 WEAR RESISTANT: Code + WR  
 HIGH PERFORMANCE: Code + WXB

# CURVAS MAGNÉTICAS / MAGNETIC CURVES

# COURBES MAGNÉTIQUES / MAGNETISCHE KURVEN

MODELO CM.0060 / MODEL CM.0060 / MODÈLE CM.0060 / MODELL CM.0060



879 M - 880 M - 881 M - 881 MX

**M** SPECIAL UHMW-PE

Segun tabla  
 According to table  
 Selon le tableau  
 Laut Tabelle

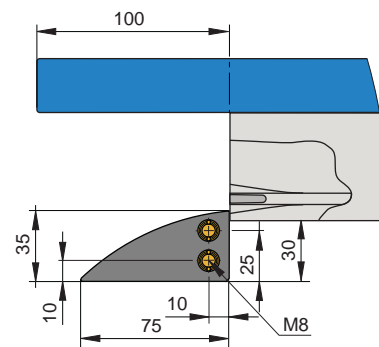
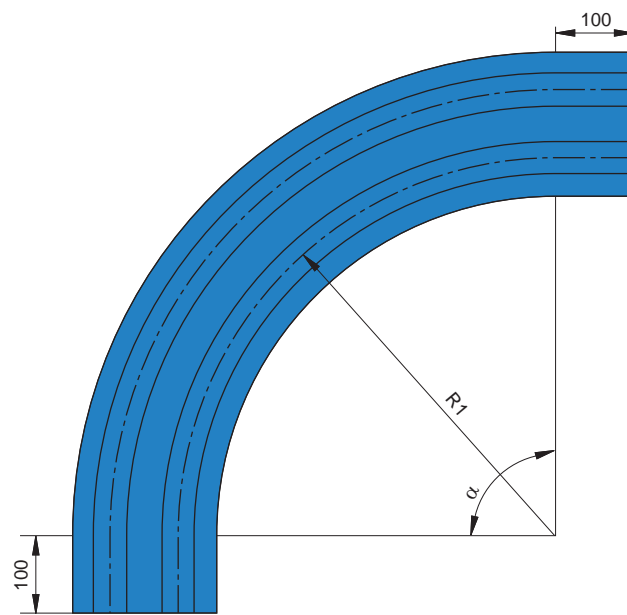
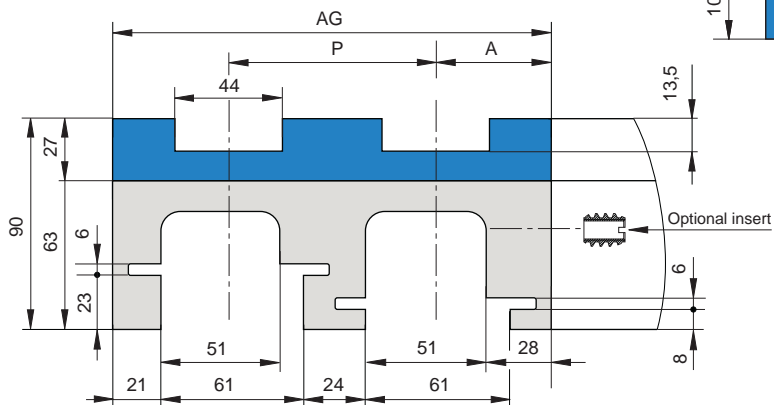
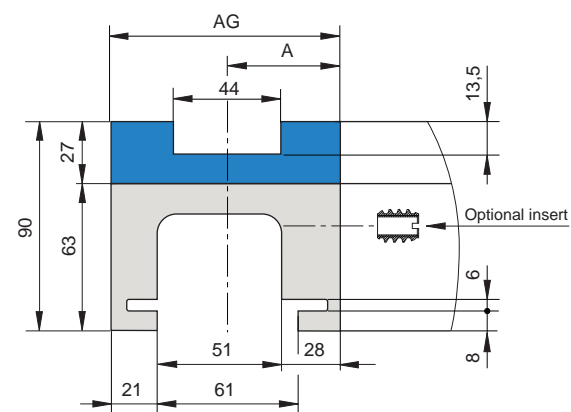
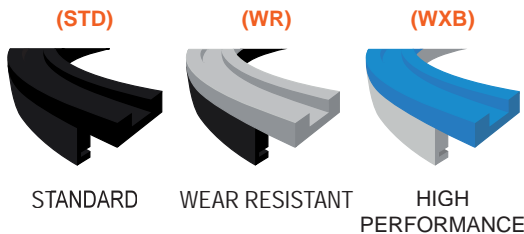
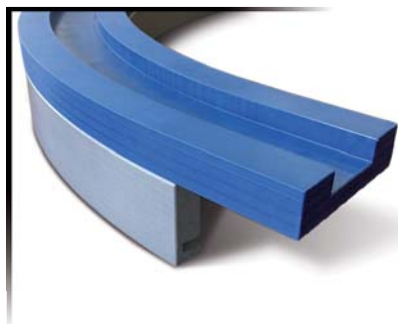

K = 82,5 - K = 83,8

P = 85mm

COD.	*MAT.	R1	A	AG	α	VIAS
CM.0060.01.90.STD	STD	500	50	100	90	1
CM.0060.02.90.STD		500	50	185	90	2
CM.0060.03.90.STD		500	50	270	90	3
CM.0060.04.90.STD		500	50	355	90	4
CM.0060.05.90.STD		500	50	440	90	5
CM.0060.06.90.STD		500	50	525	90	6

\* OTHER MATERIALS  
 WEAR RESISTANT: Code + WR  
 HIGH PERFORMANCE: Code + WXB

MODELO CM.B360 / MODEL CM.B360 / MODÈLE CM.B360 / MODELL CM.B360

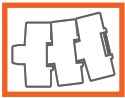

2503FTM - 2503FGM

**M** SPECIAL UHMW-PE

Segun tabla  
 According to table  
 Selon le tableau  
 Laut Tabelle

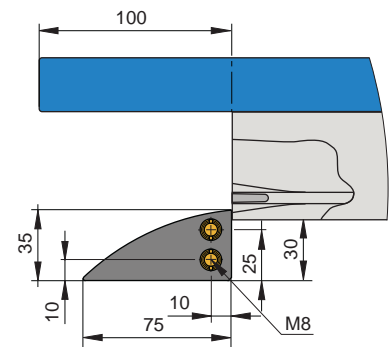
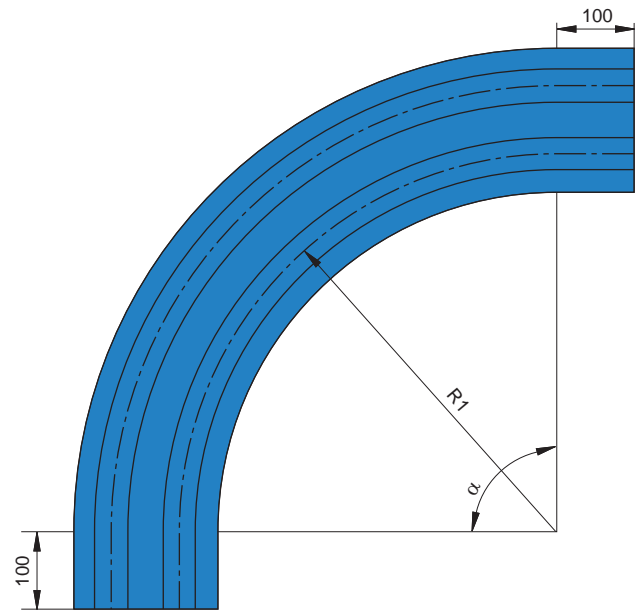
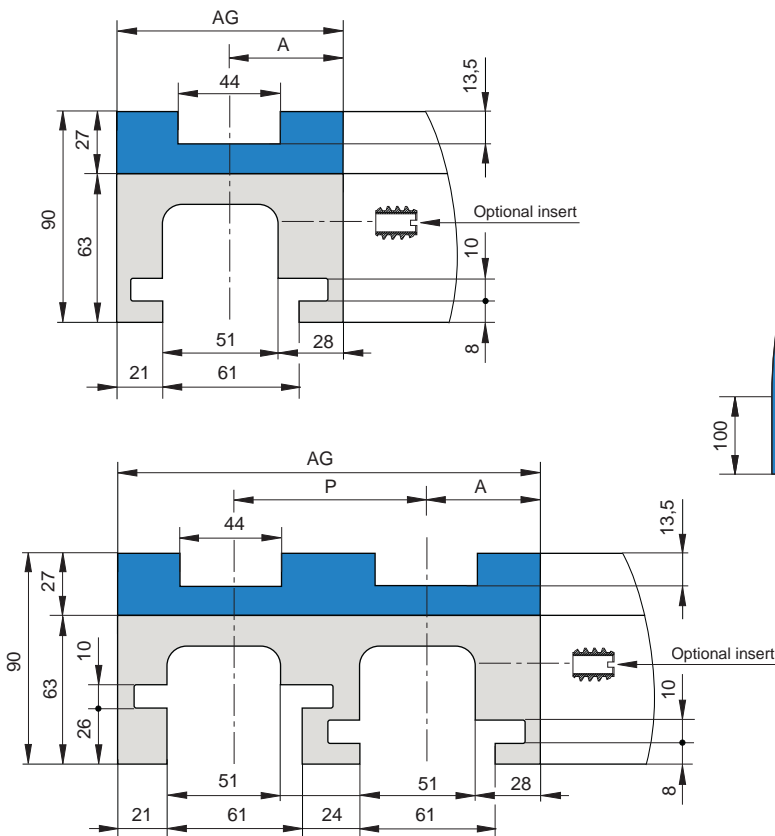
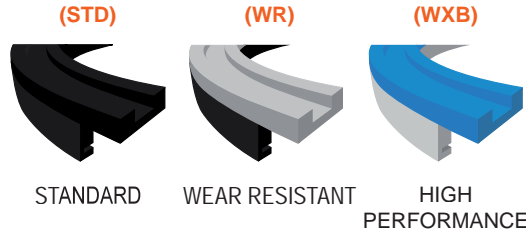
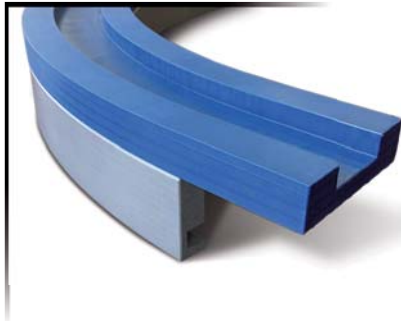

K = 83,8

P = 85mm

COD.	*MAT.	R1	A	AG	α	VIAS
CM.B360.01.90.STD	STD	500	50	100	90	1
CM.B360.02.90.STD		500	50	185	90	2
CM.B360.03.90.STD		500	50	270	90	3
CM.B360.04.90.STD		500	50	355	90	4
CM.B360.05.90.STD		500	50	440	90	5
CM.B360.06.90.STD		500	50	525	90	6

\* OTHER MATERIALS  
 WEAR RESISTANT: Code + WR  
 HIGH PERFORMANCE: Code + WXB

MODELO CM.B560 / MODEL CM.B560 / MODÈLE CM.B560 / MODELL CM.B560



2505FTM - 2505FGM

**M** SPECIAL UHMW-PE

Segun tabla  
 According to table  
 Selon le tableau  
 Laut Tabelle

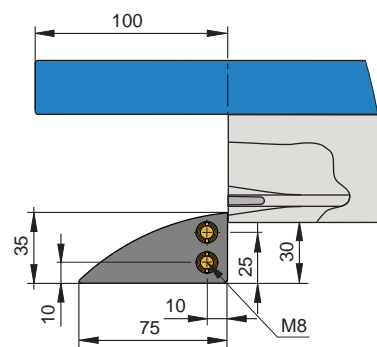
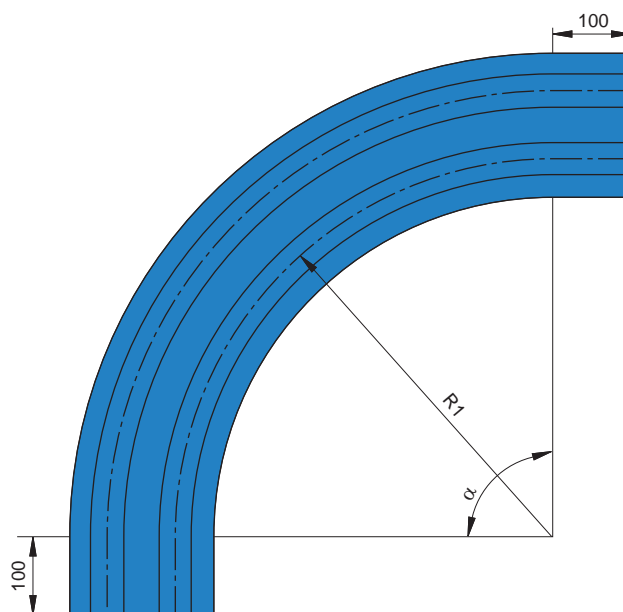
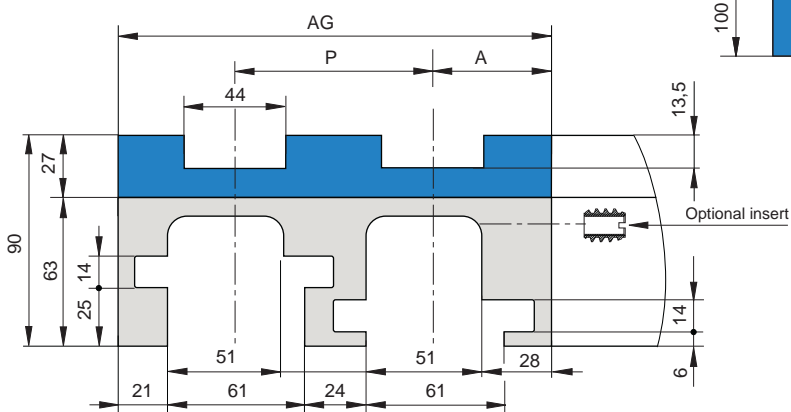
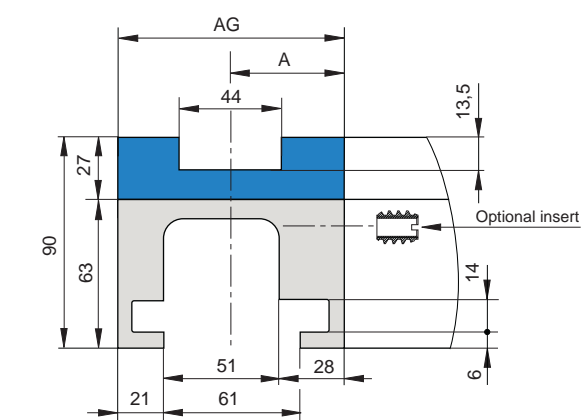
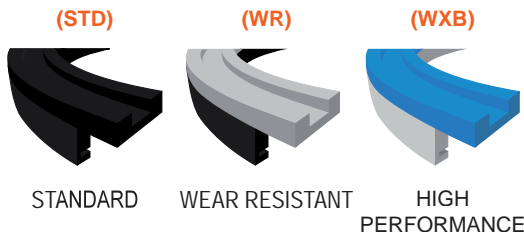
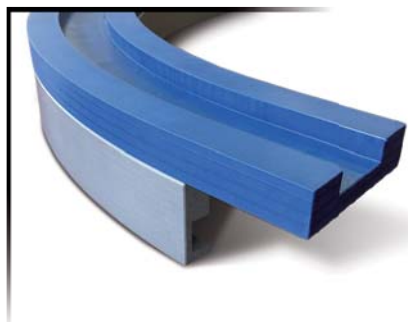

K = 83,8

P = 85mm

COD.	*MAT.	R1	A	AG	α	VIAS
CM.B560.01.90.STD	STD	500	50	100	90	1
CM.B560.02.90.STD		500	50	185	90	2
CM.B560.03.90.STD		500	50	270	90	3
CM.B560.04.90.STD		500	50	355	90	4
CM.B560.05.90.STD		500	50	440	90	5
CM.B560.06.90.STD		500	50	525	90	6

\* OTHER MATERIALS  
 WEAR RESISTANT: Code + WR  
 HIGH PERFORMANCE: Code + WXB

# CURVAS MAGNÉTICAS / MAGNETIC CURVES

# COURBES MAGNÉTIQUES / MAGNETISCHE KURVEN

MODELO CM.0040 / MODEL CM.0040 / MODÈLE CM.0040 / MODELL CM.0040



879 M - 880 M - 881 M - 881 MX

**M** SPECIAL UHMW-PE

Segun tabla  
 According to table  
 Selon le tableau  
 Laut Tabelle

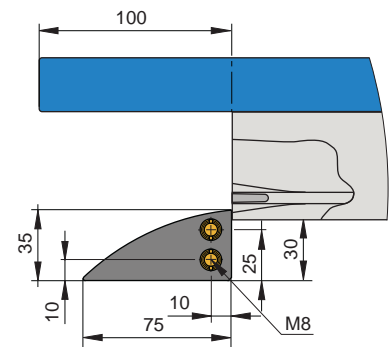
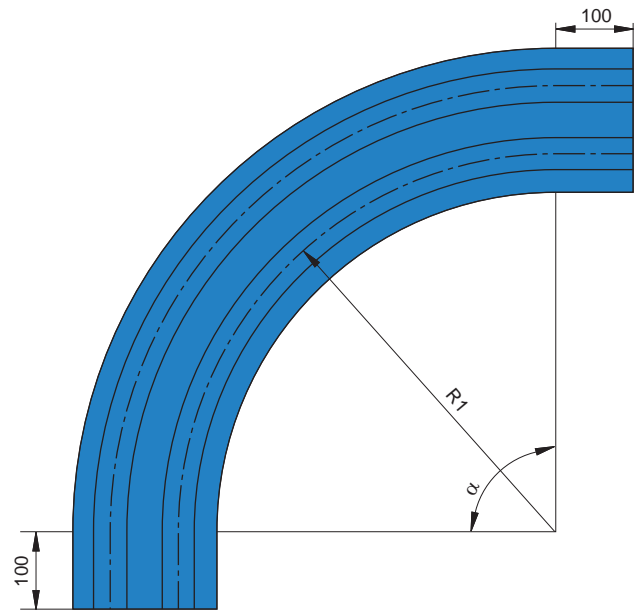
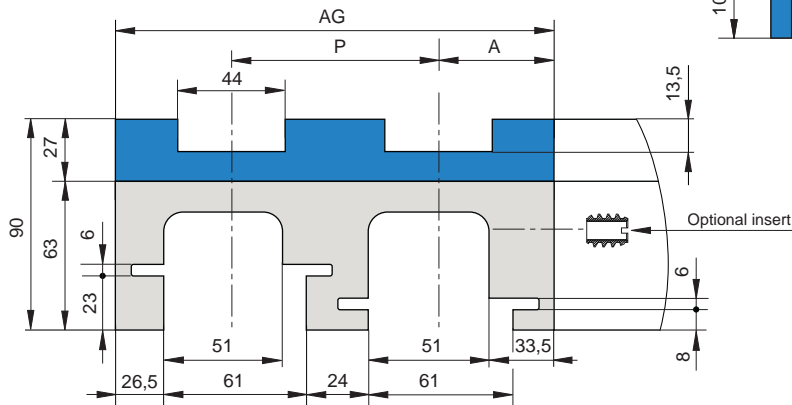
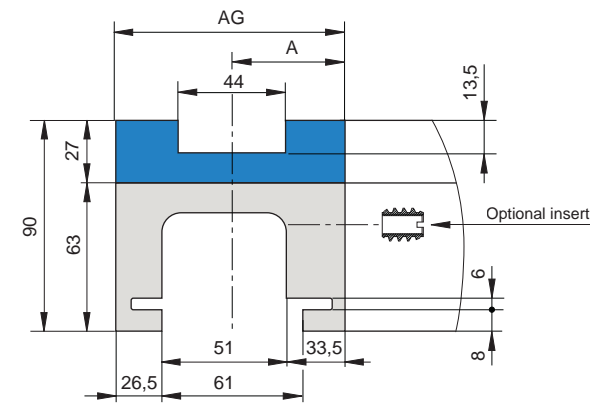
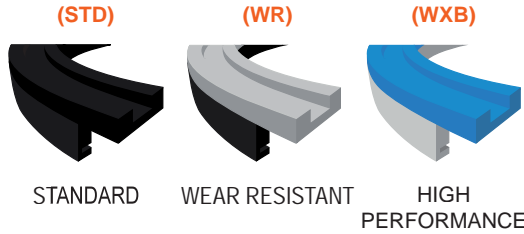
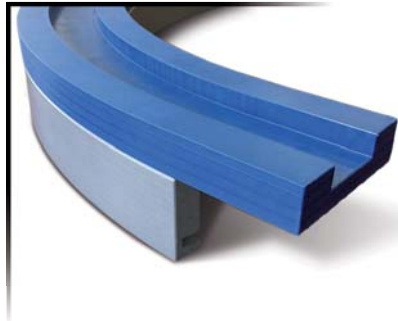

K = 82,5 - K = 83,8

P = 85mm

COD.	*MAT.	R1	A	AG	α	VIAS
CM.0040.01.90.STD	STD	500	55,5	111	90	1
CM.0040.02.90.STD		500	55,5	196	90	2
CM.0040.03.90.STD		500	55,5	281	90	3
CM.0040.04.90.STD		500	55,5	366	90	4
CM.0040.05.90.STD		500	55,5	451	90	5
CM.0040.06.90.STD		500	55,5	536	90	6

\* OTHER MATERIALS  
 WEAR RESISTANT: Code + WR  
 HIGH PERFORMANCE: Code + WXB

# CURVAS MAGNÉTICAS / MAGNETIC CURVES

# COURBES MAGNÉTIQUES / MAGNETISCHE KURVEN

MODELO CM.0014 / MODEL CM.0014 / MODÈLE CM.0014 / MODELL CM.0014

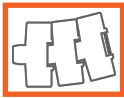

879 M - 880 M - 881 M - 881 MX

**M** SPECIAL UHMW-PE

Segun tabla  
 According to table  
 Selon le tableau  
 Laut Tabelle

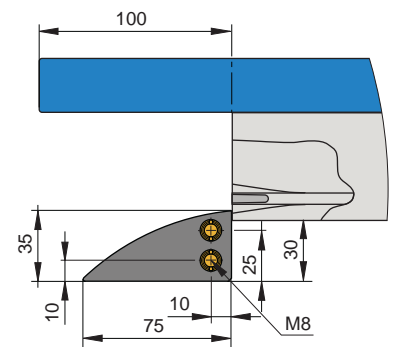
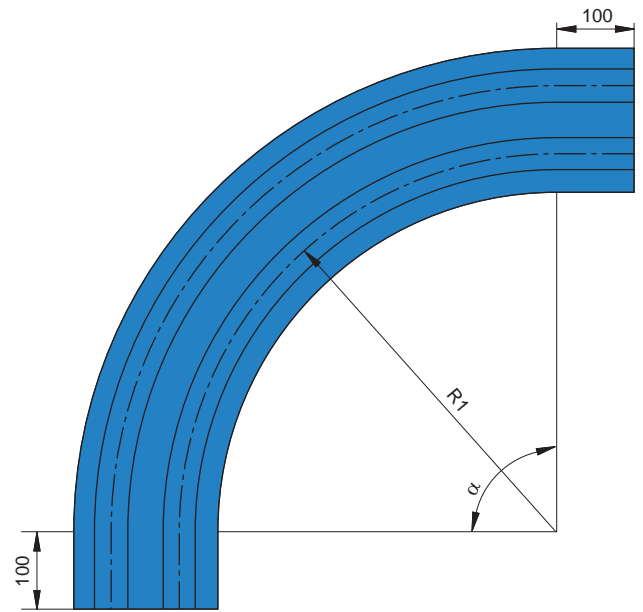
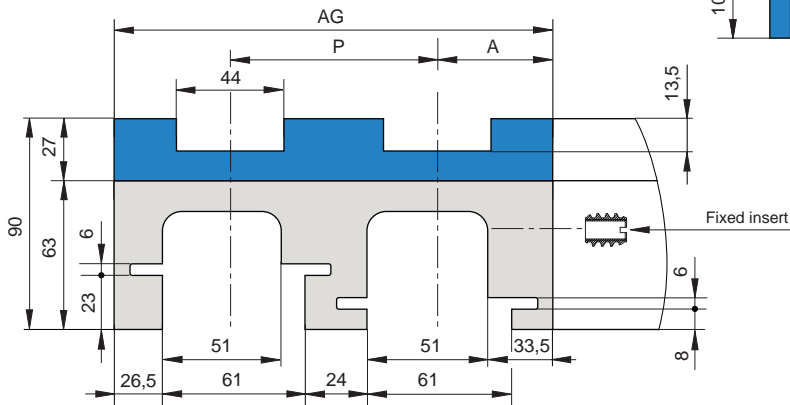
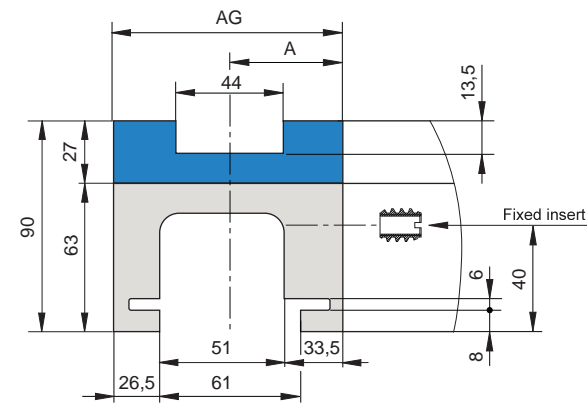
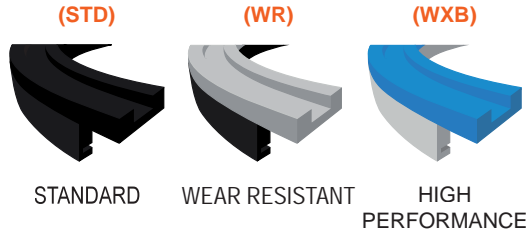
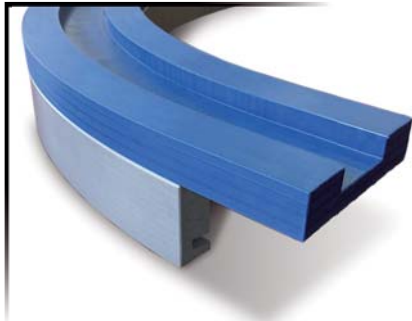

K = 82,5 - K = 83,8

P = 85mm

COD.	*MAT.	R1	A	AG	α	VIAS
CM.0014.01.90.STD	STD	500	55,5	111	90	1
CM.0014.02.90.STD		500	55,5	196	90	2
CM.0014.03.90.STD		500	55,5	281	90	3
CM.0014.04.90.STD		500	55,5	366	90	4
CM.0014.05.90.STD		500	55,5	451	90	5
CM.0014.06.90.STD		500	55,5	536	90	6

\* OTHER MATERIALS  
 WEAR RESISTANT: Code + WR  
 HIGH PERFORMANCE: Code + WXB

# CURVAS MAGNÉTICAS / MAGNETIC CURVES

# COURBES MAGNÉTIQUES / MAGNETISCHE KURVEN

MODELO CM.0010 / MODEL CM.0010 / MODÈLE CM.0010 / MODELL CM.0010



879 M - 880 M - 881 M - 881 MX

**M** SPECIAL UHMW-PE

Según tabla  
 According to table  
 Selon le tableau  
 Laut Tabelle

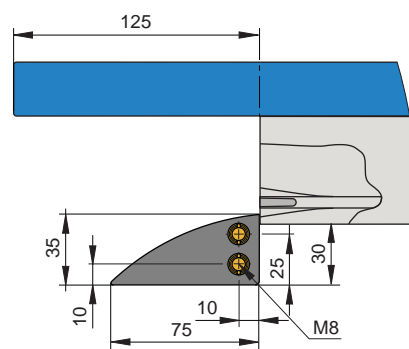
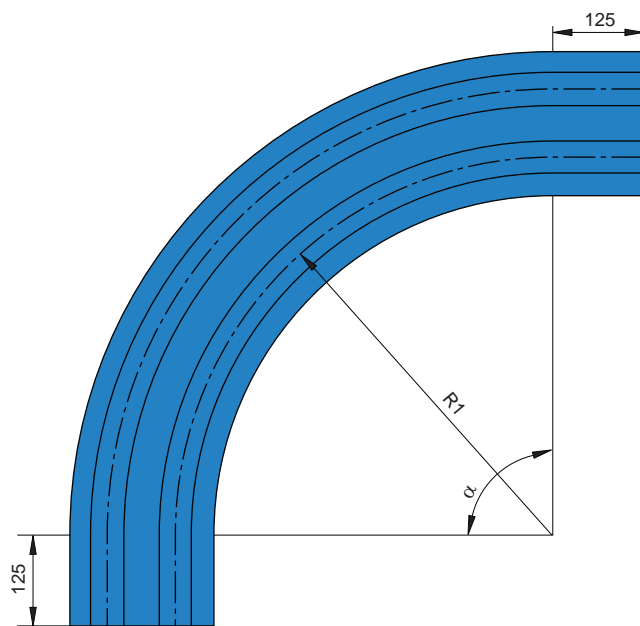
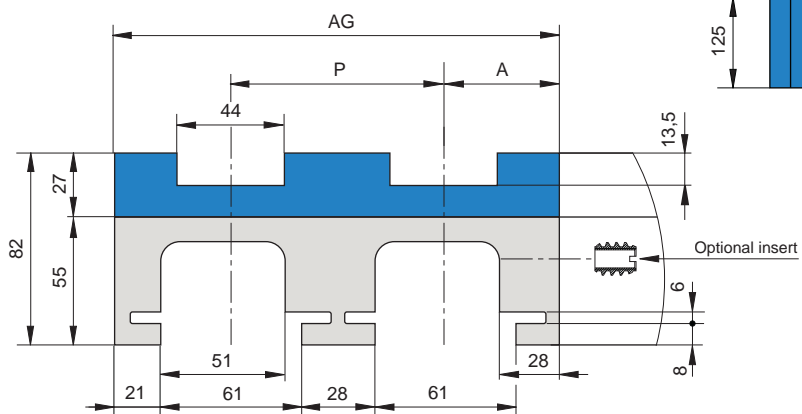
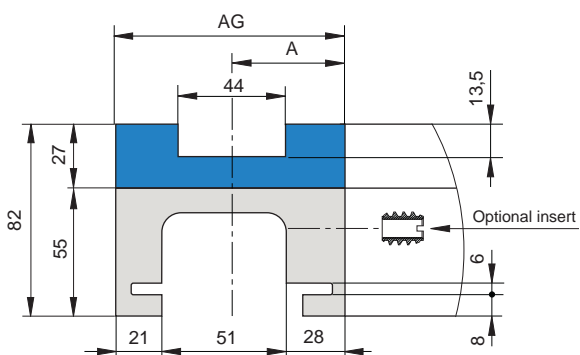
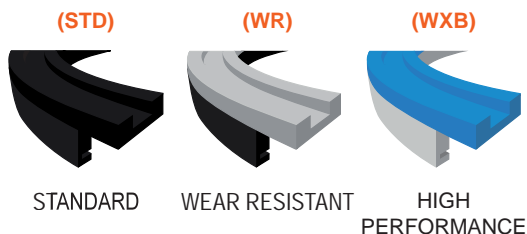
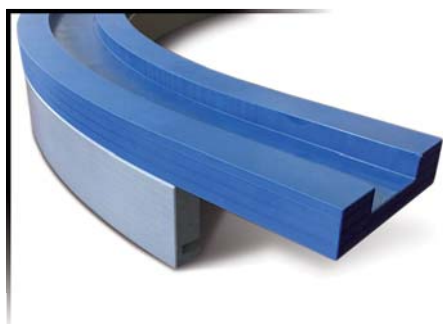

K = 82,5 - K = 83,8

P = 89mm

COD.	*MAT.	R1	A	AG	α	VIAS
CM.0010.01.90.STD	STD	500	50	100	90	1
CM.0010.02.90.STD		500	50	189	90	2
CM.0010.03.90.STD		500	50	278	90	3
CM.0010.04.90.STD		500	50	367	90	4
CM.0010.05.90.STD		500	50	456	90	5
CM.0010.06.90.STD		500	50	545	90	6

\* OTHER MATERIALS  
 WEAR RESISTANT: Code + WR  
 HIGH PERFORMANCE: Code + WXB

MODELO CM.0030 / MODEL CM.0030 / MODÈLE CM.0030 / MODELL CM.0030

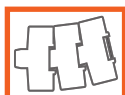

879 M - 880 M - 881 M - 881 MX

**M** SPECIAL UHMW-PE

Segun tabla  
 According to table  
 Selon le tableau  
 Laut Tabelle

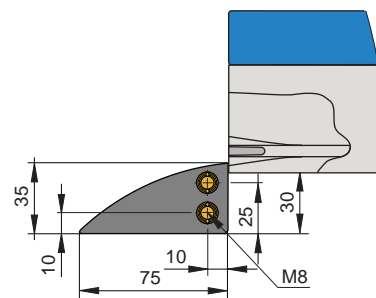
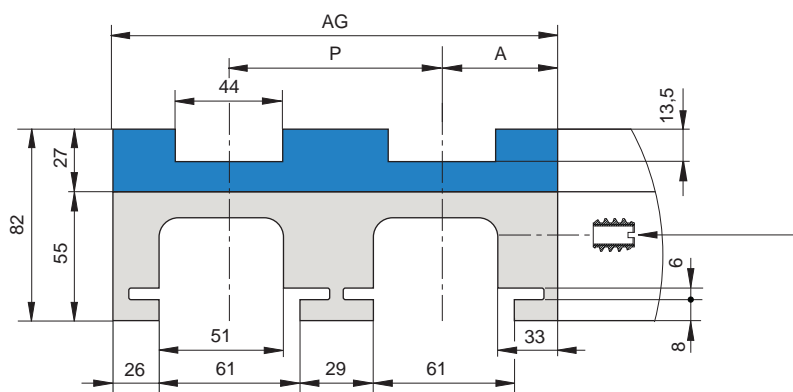
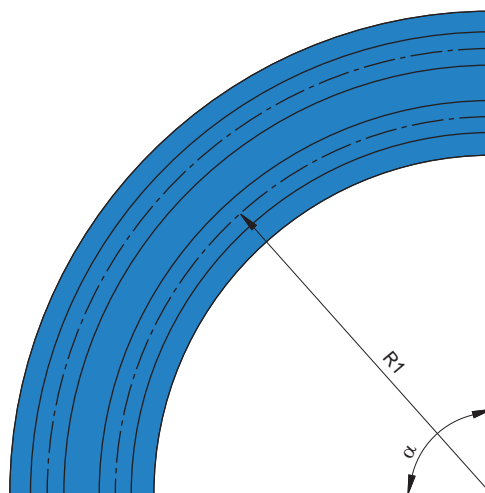
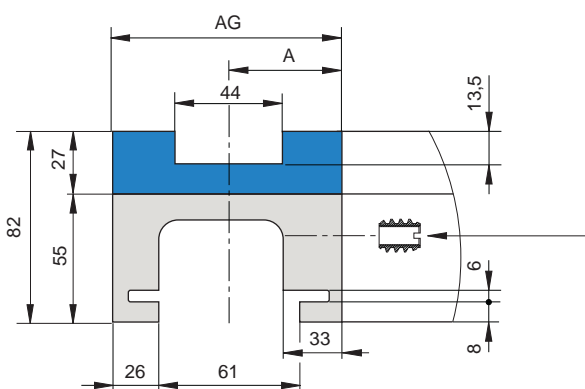
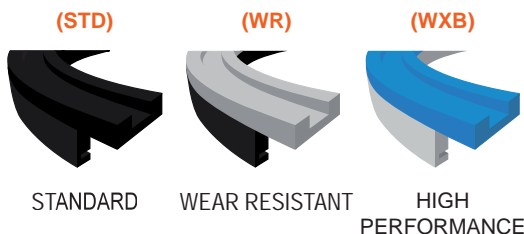
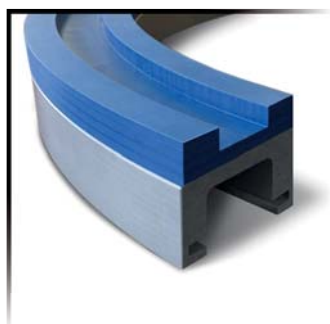

K = 82,5 - K = 83,8

P = 90mm

COD.	*MAT.	R1	A	AG	α	VIAS
CM.0030.01.90.STD	STD	500	55	110	90	1
CM.0030.02.90.STD		500	55	200	90	2
CM.0030.03.90.STD		500	55	290	90	3
CM.0030.04.90.STD		500	55	380	90	4
CM.0030.05.90.STD		500	55	470	90	5
CM.0030.06.90.STD		500	55	560	90	6

\* OTHER MATERIALS  
 WEAR RESISTANT: Code + WR  
 HIGH PERFORMANCE: Code + WXB

# CURVAS MAGNÉTICAS / MAGNETIC CURVES

# COURBES MAGNÉTIQUES / MAGNETISCHE KURVEN

MODELO CM.0020 / MODEL CM.0020 / MODÈLE CM.0020 / MODELL CM.0020



879 M - 880 M - 881 M - 881 MX

**M** SPECIAL UHMW-PE  
 Segun tabla  
 According to table  
 Selon le tableau  
 Laut Tabelle

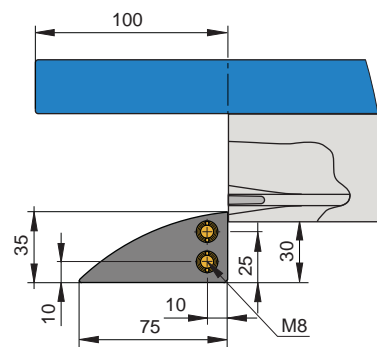
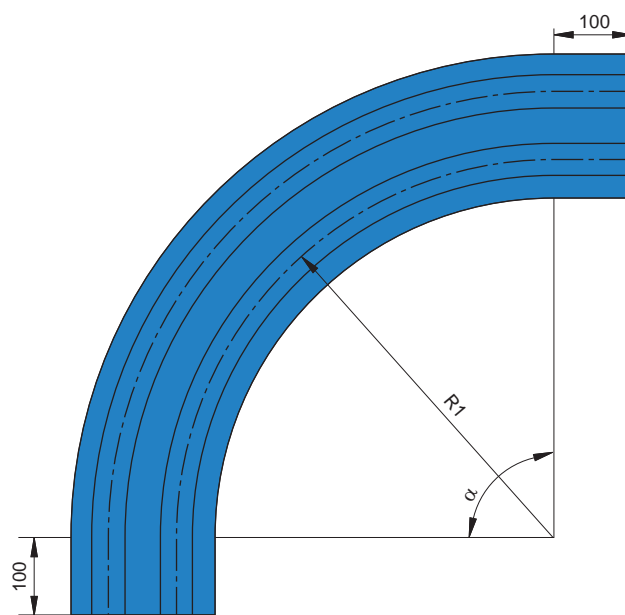
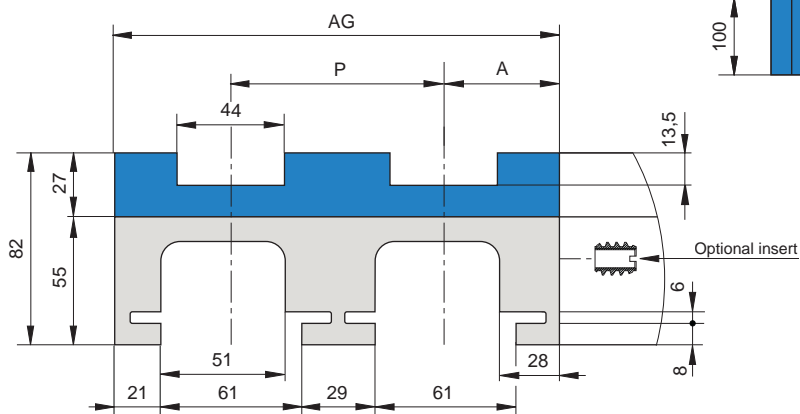
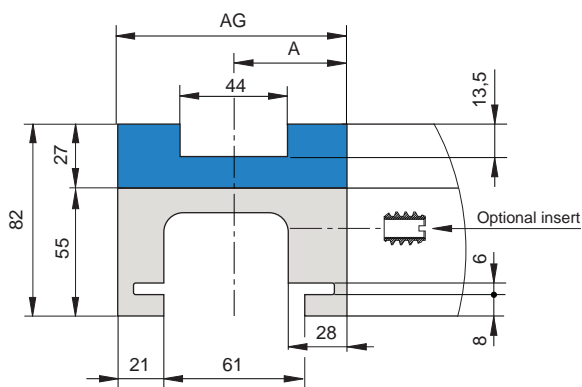
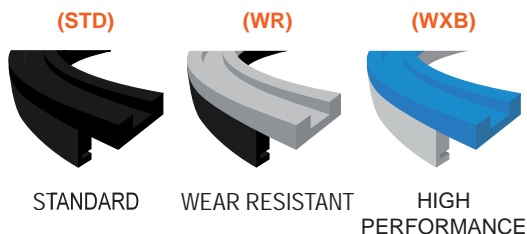
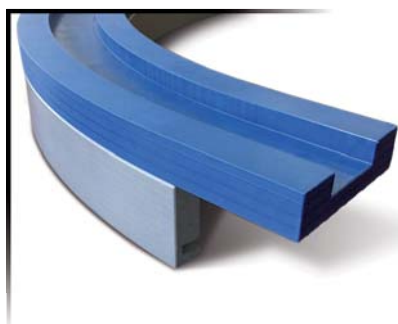

K = 82,5 - K = 83,8

P = 90mm

COD.	*MAT.	R1	A	AG	α	VIAS
CM.0020.01.90.STD	STD	500	50	100	90	1
CM.0020.02.90.STD		500	50	190	90	2
CM.0020.03.90.STD		500	50	280	90	3
CM.0020.04.90.STD		500	50	370	90	4
CM.0020.05.90.STD		500	50	460	90	5
CM.0020.06.90.STD		500	50	550	90	6

\* OTHER MATERIALS  
 WEAR RESISTANT: Code + WR  
 HIGH PERFORMANCE: Code + WXB

MODELO CM.0211 / MODEL CM.0211 / MODÈLE CM.0211 / MODELL CM.0211



879 M - 880 M - 881 M - 881 MX

**M** SPECIAL UHMW-PE

 Según tabla  
 According to table  
 Selon le tableau  
 Laut Tabelle

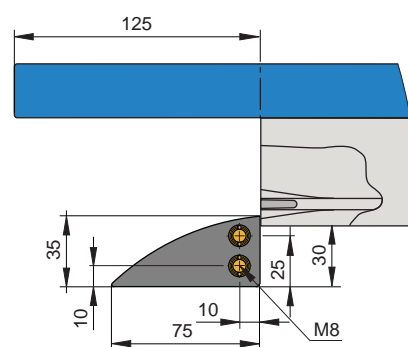
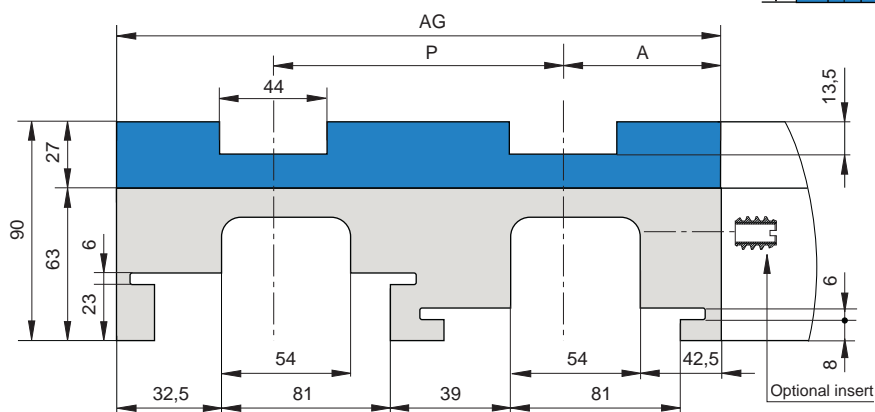
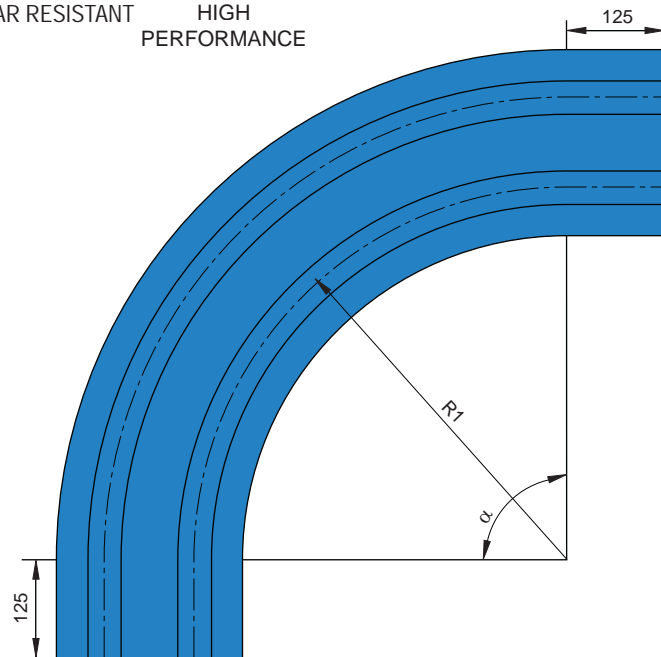
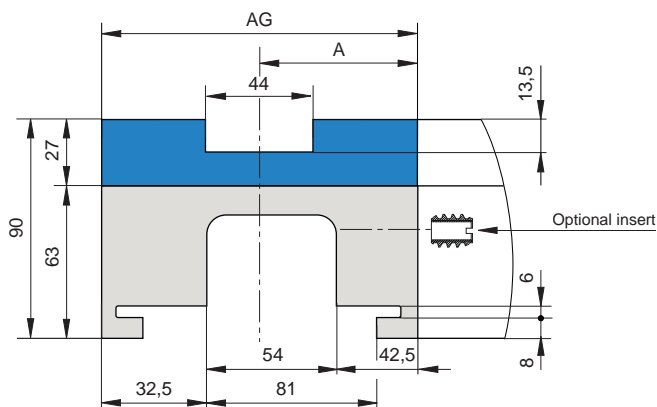
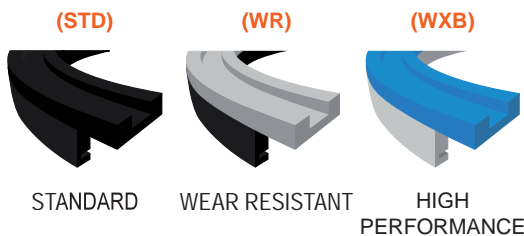
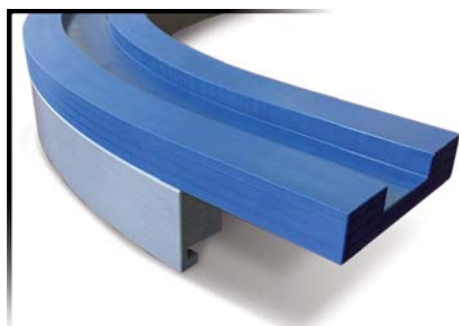

K = 114,3

P = 120mm

COD.	* MAT.	R1	A	AG	α	VIAS
CM.0211.01.90.STD	STD	500	64,5	129	90	1
CM.0211.02.90.STD		500	64,5	249	90	2
CM.0211.03.90.STD		500	64,5	369	90	3
CM.0211.04.90.STD		500	64,5	489	90	4

\* OTHER MATERIALS  
 WEAR RESISTANT: Code + WR  
 HIGH PERFORMANCE: Code + WXB

MODELO CM.B521 / MODEL CM.B521 / MODÈLE CM.B521 / MODELL CM.B521



2505FTM - 2505FGM

**M** SPECIAL UHMW-PE  
 Según tabla  
 According to table  
 Selon le tableau  
 Laut Tabelle

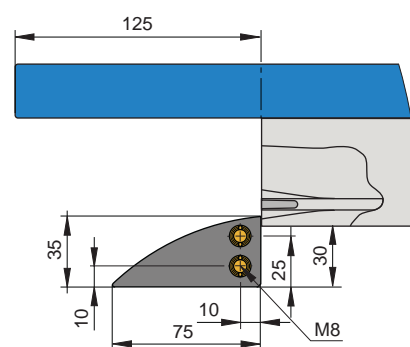
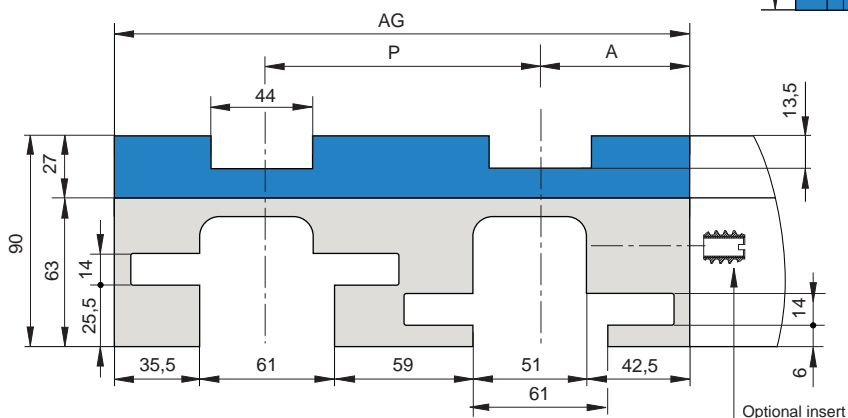
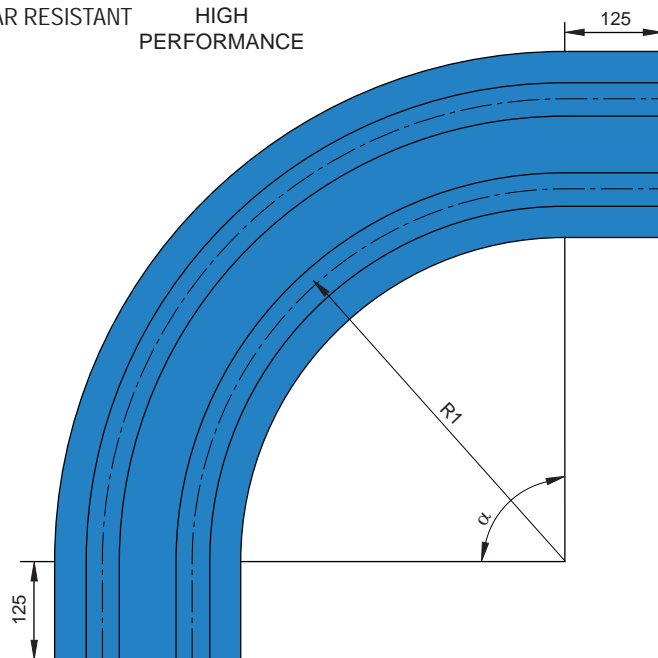
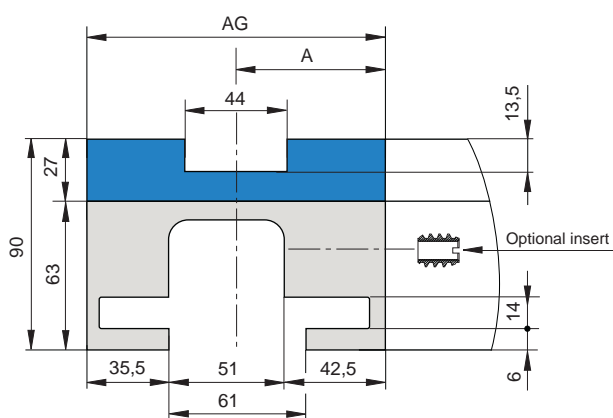
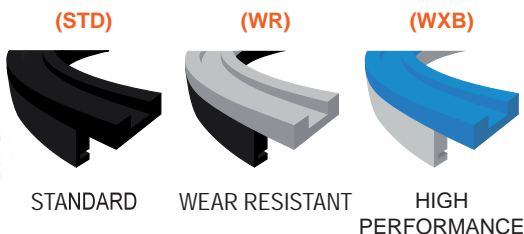
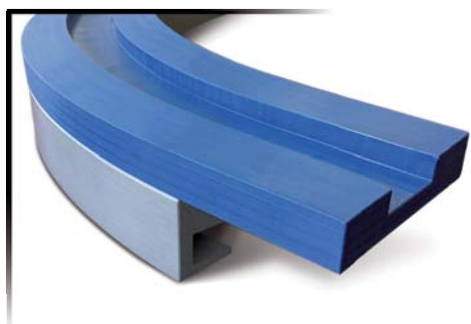

K = 114,3

P = 120mm

COD.	*MAT.	R1	A	AG	α	VIAS
CM.B521.01.90.STD	STD	500	64,5	129	90	1
CM.B521.02.90.STD		500	64,5	249	90	2
CM.B521.03.90.STD		500	64,5	369	90	3
CM.B521.04.90.STD		500	64,5	489	90	4
CM.B521.05.90.STD		500	64,5	609	90	5
CM.B521.06.90.STD		500	64,5	729	90	6

\* OTHER MATERIALS  
 WEAR RESISTANT: Code + WR  
 HIGH PERFORMANCE: Code + WXB

# CURVAS MAGNÉTICAS / MAGNETIC CURVES

# COURBES MAGNÉTIQUES / MAGNETISCHE KURVEN

MODELO CM.0221 / MODEL CM.0221 / MODÈLE CM.0221 / MODELL CM.0221



879 M - 880 M - 881 M - 881 MX

**M** SPECIAL UHMW-PE

Según tabla  
 According to table  
 Selon le tableau  
 Laut Tabelle

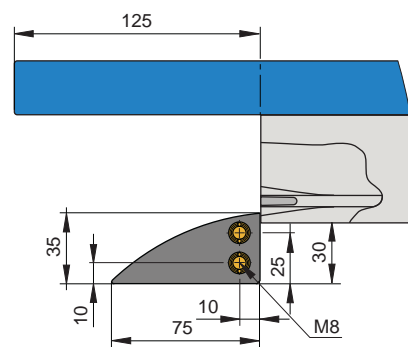
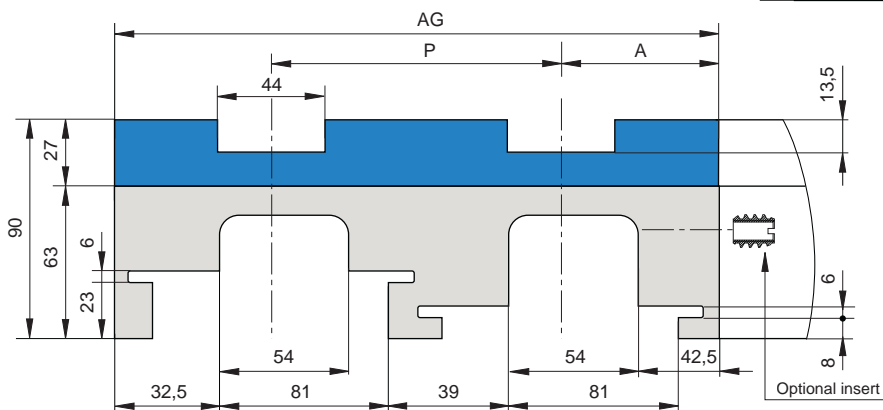
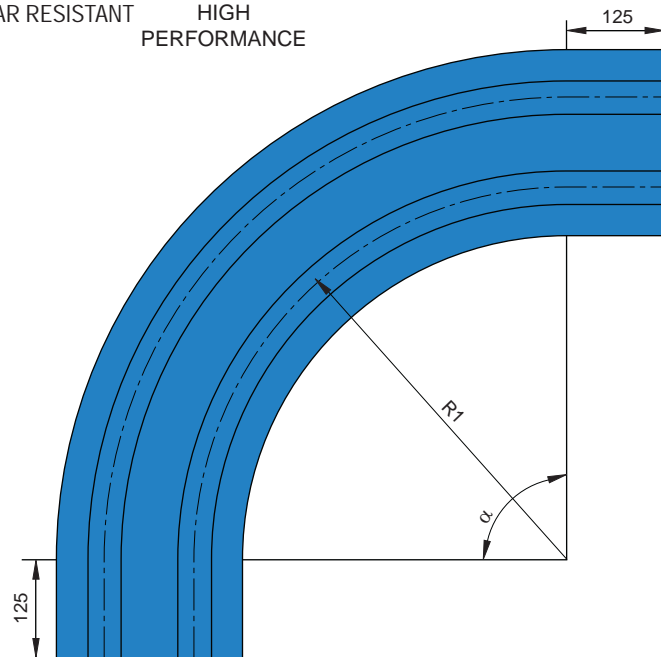
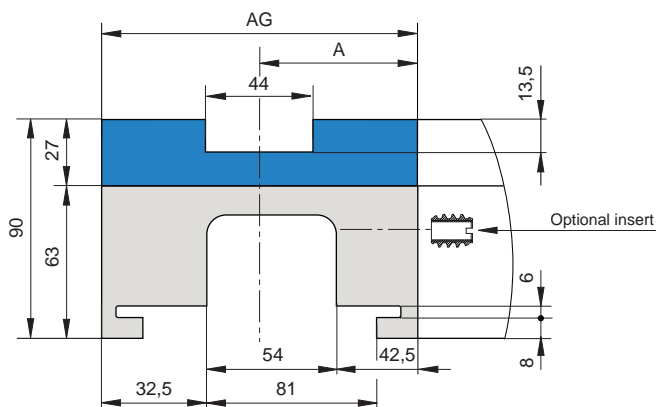
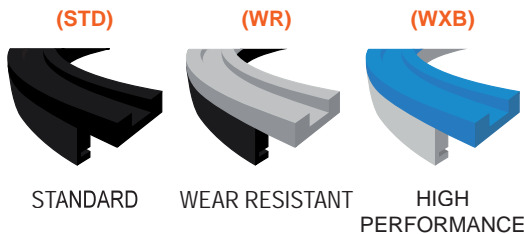
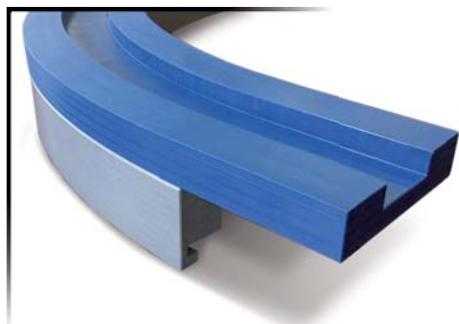

K = 114,3

P = 120mm

COD.	*MAT.	R1	A	AG	α	VIAS
CM.0221.01.90.STD	STD	610	64,5	129	90	1
CM.0221.02.90.STD		610	64,5	249	90	2
CM.0221.03.90.STD		610	64,5	369	90	3
CM.0221.04.90.STD		610	64,5	489	90	4

\* OTHER MATERIALS

WEAR RESISTANT: Code + WR  
 HIGH PERFORMANCE: Code + WXB

MODELO CM.0810 / MODEL CM.0810 / MODÈLE CM.0810 / MODELL CM.0810

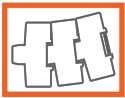

8875 M - 882 M

**M** SPECIAL UHMW-PE

Segun tabla  
 According to table  
 Selon le tableau  
 Laut Tabelle

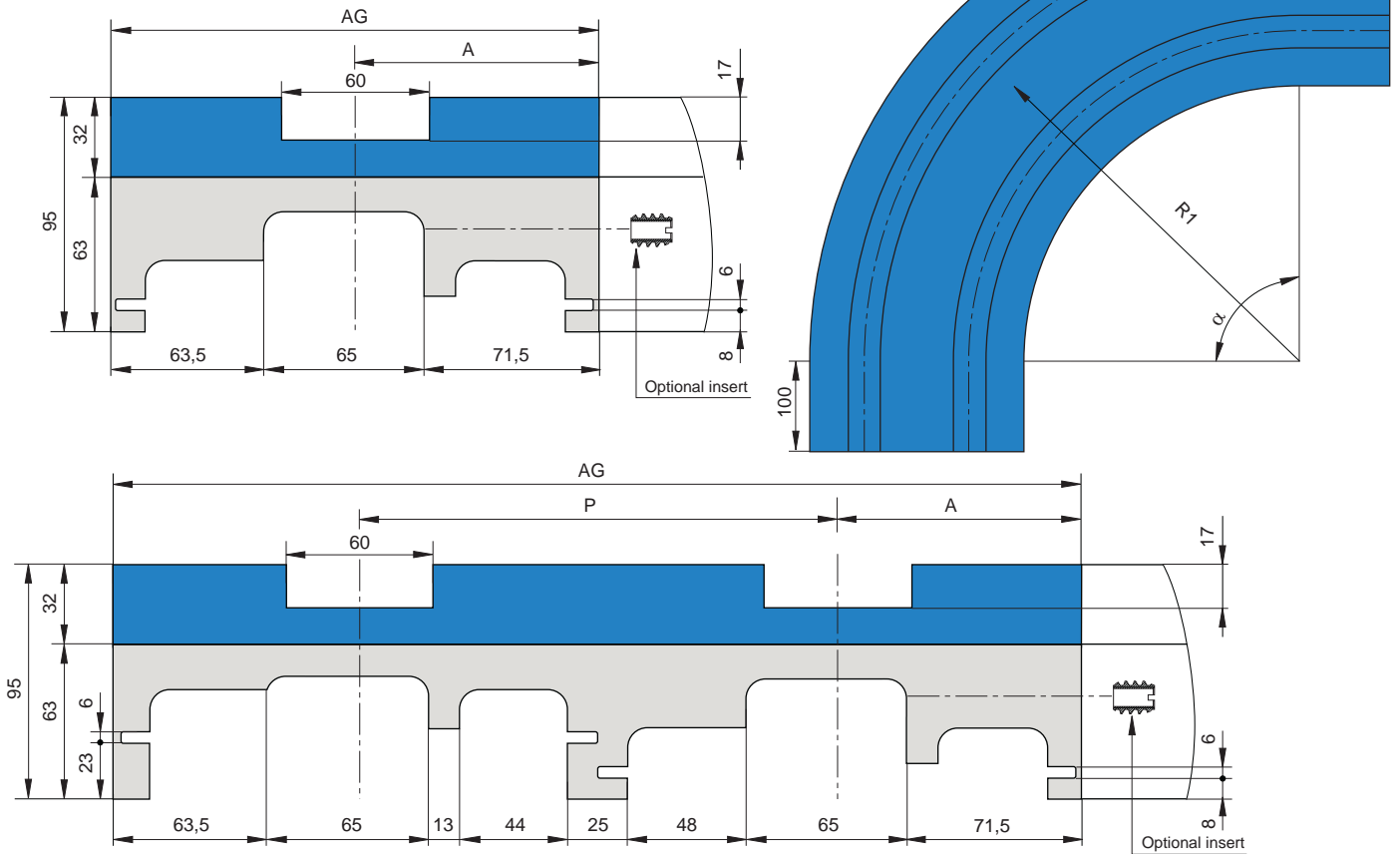
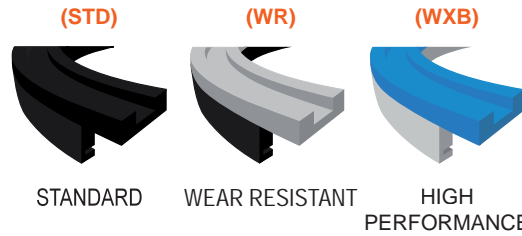
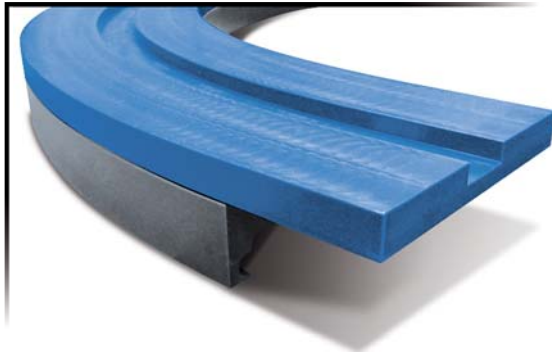

K = 190,5

P = 195mm

COD.	*MAT.	R1	A	AG	α	VIAS
CM.0810.01.90.STD	STD	610	100	200	90	1
CM.0810.02.90.STD		610	100	395	90	2
CM.0810.03.90.STD		610	100	590	90	3
CM.0810.04.90.STD		610	100	785	4	

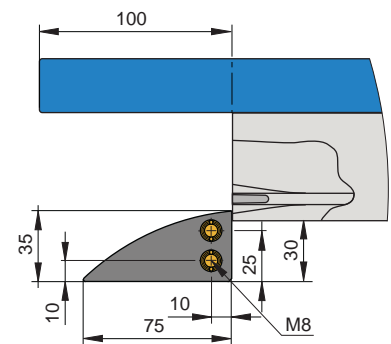

\* OTHER MATERIALS

WEAR RESISTANT: Code + WR

HIGH PERFORMANCE: Code + WXB

MODELO CM.0610 / MODEL CM.0610 / MODÈLE CM.0610 / MODELL CM.0610



881 M

**M** SPECIAL UHMW-PE

Segun tabla  
 According to table  
 Selon le tableau  
 Laut Tabelle

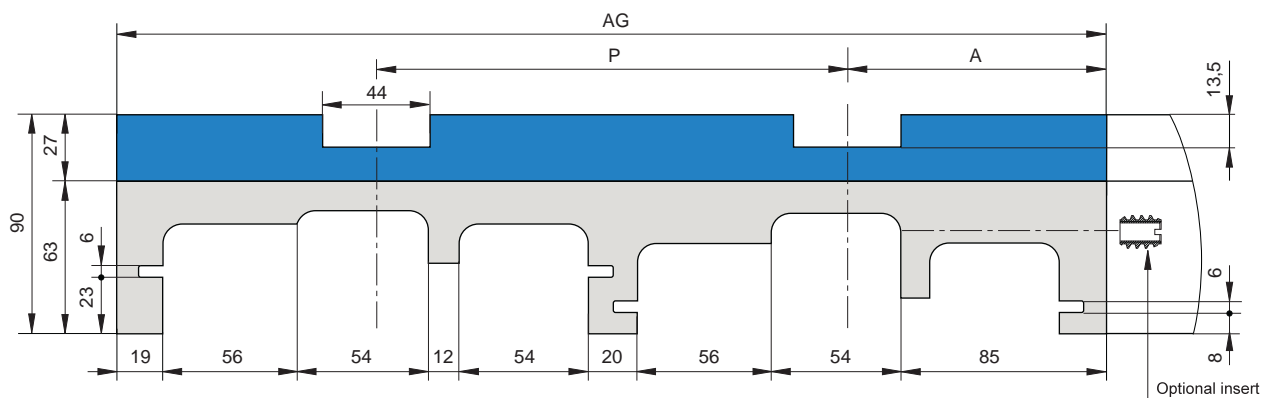
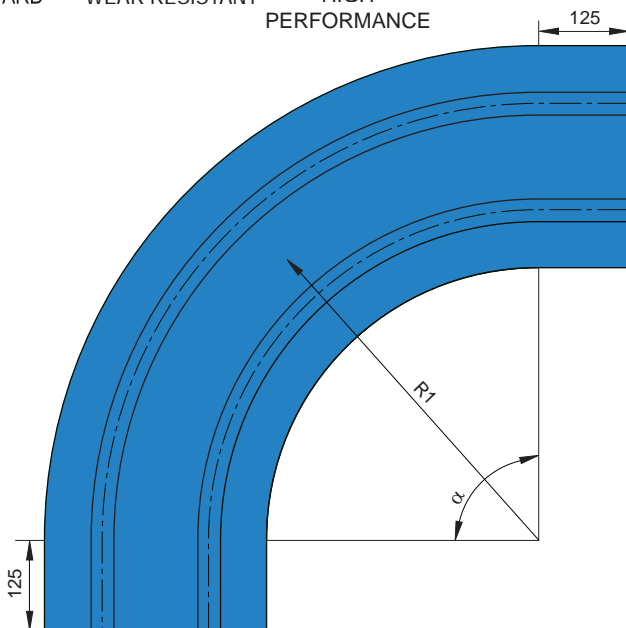
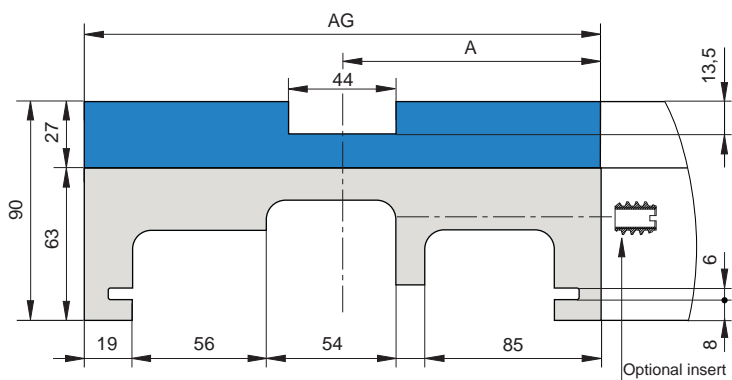
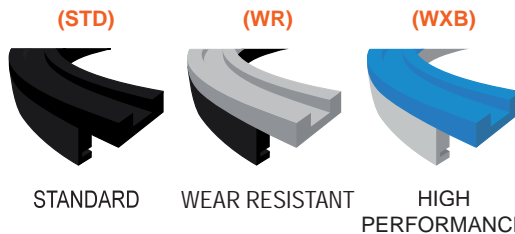
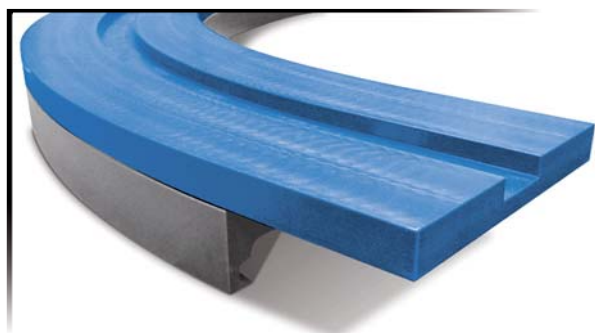

K = 190,5

P = 196mm

COD.	* MAT.	R1	A	AG	α	VIAS
CM.0610.01.90.STD	STD	610	107	214	90	1
CM.0610.02.90.STD		610	107	410	90	2
CM.0610.03.90.STD		610	107	606	90	3
CM.0610.04.90.STD		610	107	802	90	4

\* OTHER MATERIALS

WEAR RESISTANT: Code + WR

HIGH PERFORMANCE: Code + WXB

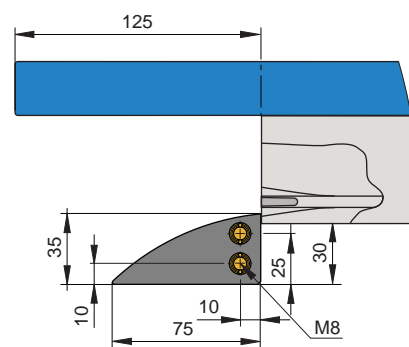

MODELO CM.0051 / MODEL CM.0051 / MODÈLE CM.0051 / MODELL CM.0051



879 M - 880 M - 881 M - 881 MX

**M** SPECIAL UHMW-PE

Según tabla  
 According to table  
 Selon le tableau  
 Laut Tabelle

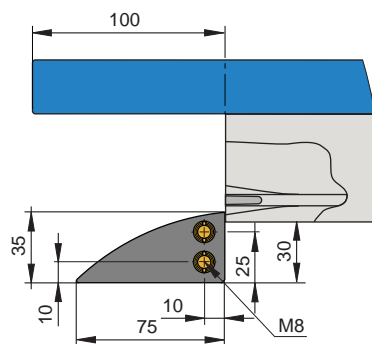
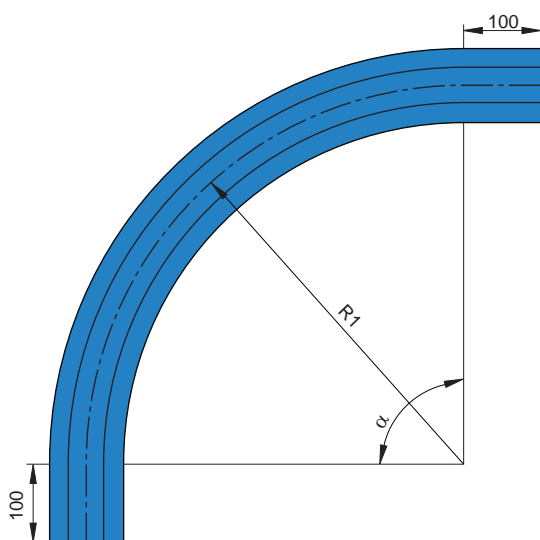
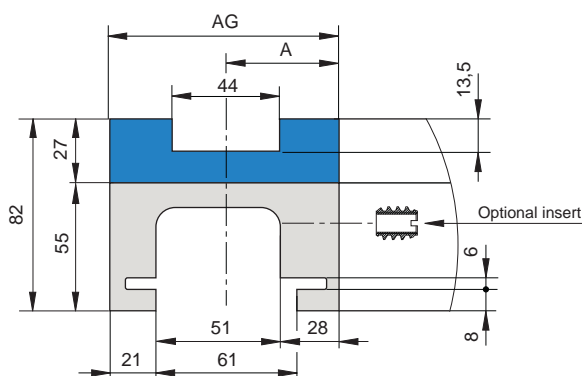
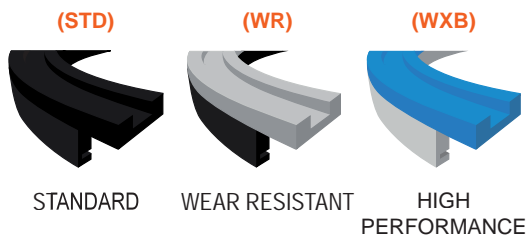
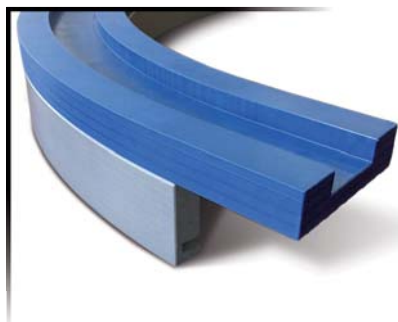

K = 82,5 - K = 83,8

COD.	*MAT.	R1	A	AG	α	VIAS
CM.0051.01.15.STD	STD	680	50	100	15	1
CM.0051.01.30.STD		680	50	100	30	1
CM.0051.01.45.STD		680	50	100	45	1
CM.0051.01.60.STD		680	50	100	60	1
CM.0051.01.75.STD		680	50	100	75	1
CM.0051.01.90.STD		680	50	100	90	1

\* OTHER MATERIALS  
 WEAR RESISTANT: Code + WR  
 HIGH PERFORMANCE: Code + WXB

# CURVAS MAGNÉTICAS / MAGNETIC CURVES

# COURBES MAGNÉTIQUES / MAGNETISCHE KURVEN

MODELO CM.0420 / MODEL CM.0420 / MODÈLE CM.0420 / MODELL CM.0420



879 M - 880 M - 881 M - 881 MX

**M** SPECIAL UHMW-PE

Según tabla  
 According to table  
 Selon le tableau  
 Laut Tabelle

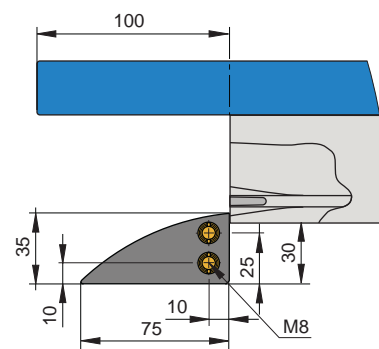
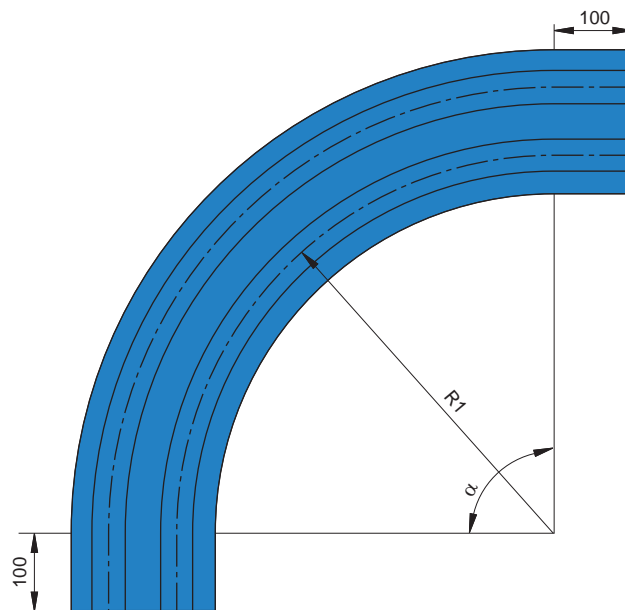
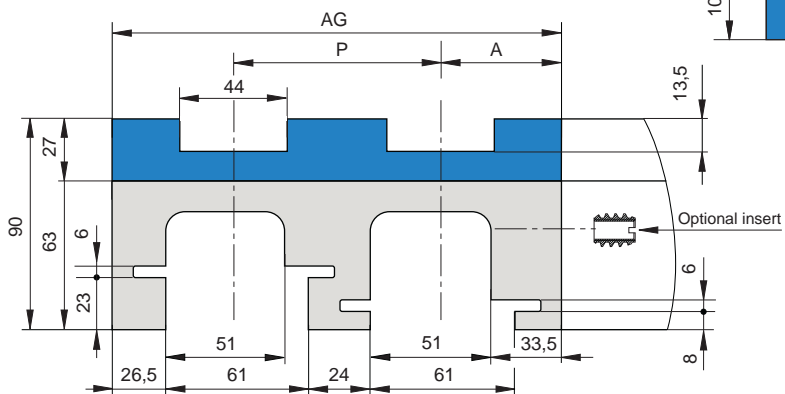
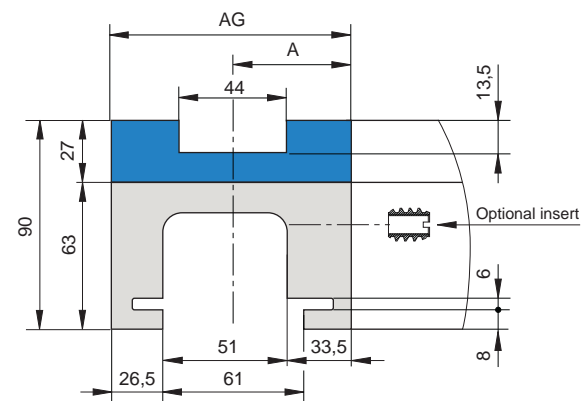
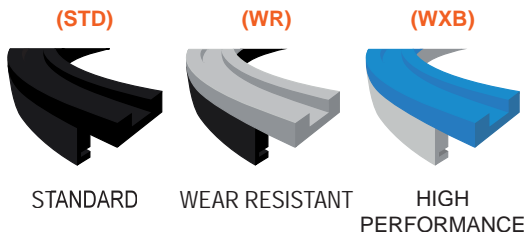
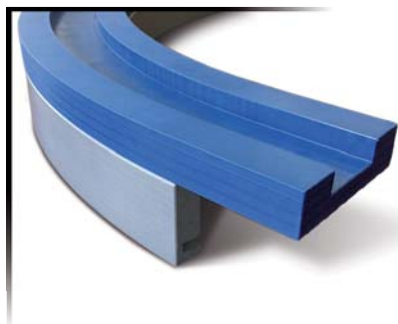

K = 82,5 - K = 83,8

P = 85mm

COD.	*MAT.	R1	A	AG	α	VIAS
CM.0420.01.90.STD	STD	750	55,5	111	90	1
CM.0420.02.90.STD		750	55,5	196	90	2
CM.0420.03.90.STD		750	55,5	281	90	3
CM.0420.04.90.STD		750	55,5	366	90	4
CM.0420.05.90.STD		750	55,5	451	90	5
CM.0420.06.90.STD		750	55,5	536	90	6

\* OTHER MATERIALS

WEAR RESISTANT: Code + WR

HIGH PERFORMANCE: Code + WXB

MODELO CM.0053 / MODEL CM.0053 / MODÈLE CM.0053 / MODELL CM.0053



879 M - 880 M - 881 M - 881 MX

**M** SPECIAL UHMW-PE

Segun tabla  
 According to table  
 Selon le tableau  
 Laut Tabelle

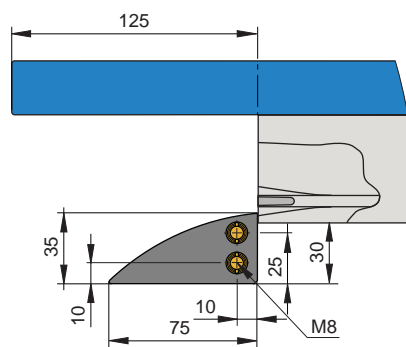
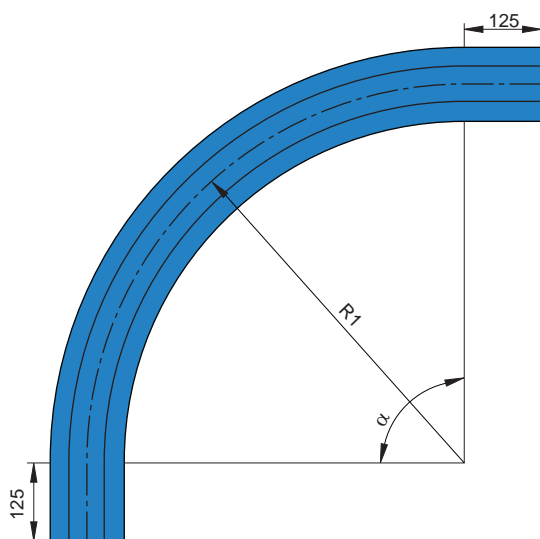
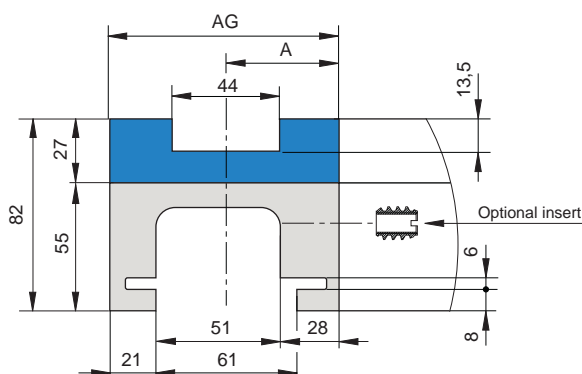
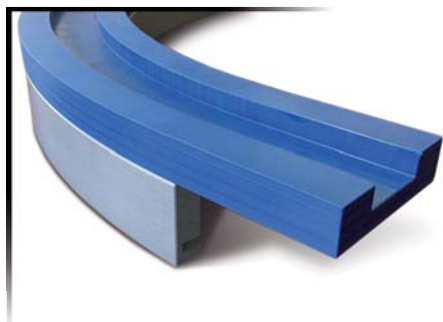

K = 82,5 - K = 83,8

COD.	*MAT.	R1	A	AG	α	VIAS
CM.0053.01.15.STD	STD	860	50	100	15	1
CM.0053.01.30.STD		860	50	100	30	1
CM.0053.01.45.STD		860	50	100	45	1
CM.0053.01.60.STD		860	50	100	60	1
CM.0053.01.75.STD		860	50	100	75	1
CM.0053.01.90.STD		860	50	100	90	1

\* OTHER MATERIALS  
 WEAR RESISTANT: Code + WR  
 HIGH PERFORMANCE: Code + WXB

MODELO CM.0860 / MODEL CM.0860 / MODÈLE CM.0860 / MODELL CM.0860



8275 M - 882 M

**M** SPECIAL UHMW-PE

Segun tabla  
 According to table  
 Selon le tableau  
 Laut Tabelle

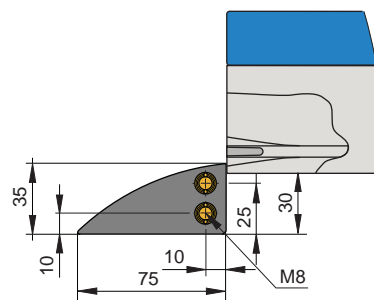
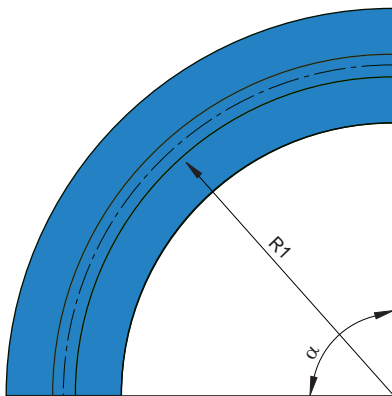
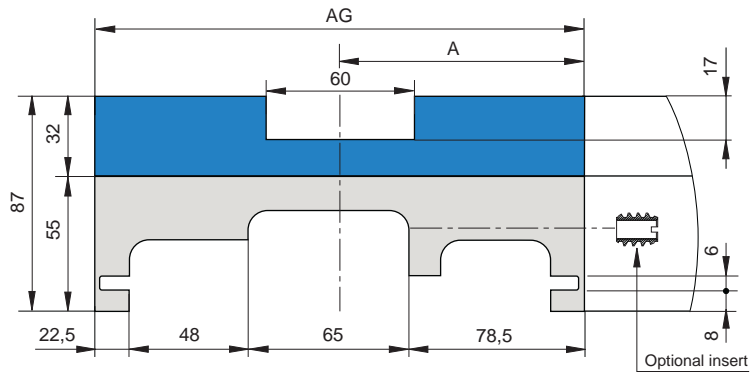
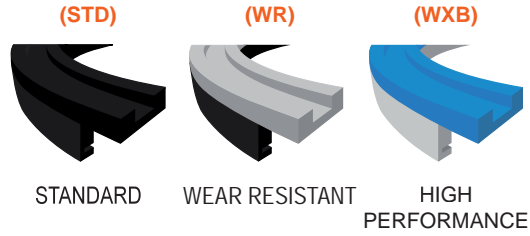
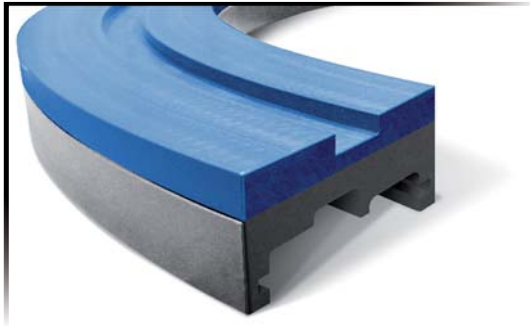

K = 190,5

COD.	*MAT.	R1	A	AG	α	VIAS
CM.0860.01.15.STD	STD	860	107	214	15	1
CM.0860.01.30.STD		860	107	214	30	1
CM.0860.01.45.STD		860	107	214	45	1
CM.0860.01.60.STD		860	107	214	60	1
CM.0860.01.75.STD		860	107	214	75	1
CM.0860.01.90.STD		860	107	214	90	1

\* OTHER MATERIALS  
 WEAR RESISTANT: Code + WR  
 HIGH PERFORMANCE: Code + WXB

MODELO CM.0660 / MODEL CM.0660 / MODÈLE CM.0660 / MODELL CM.0660



881 M

**M** SPECIAL UHMW-PE

Segun tabla  
 According to table  
 Selon le tableau  
 Laut Tabelle

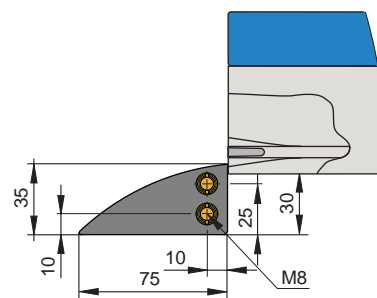
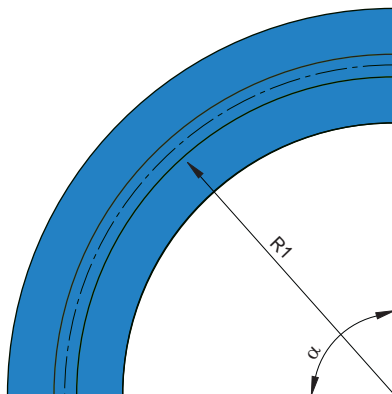
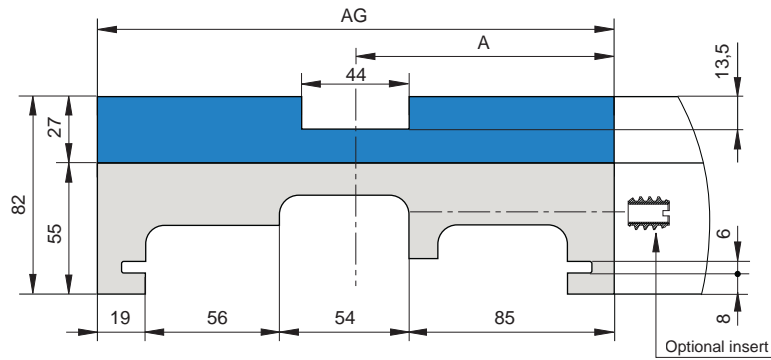
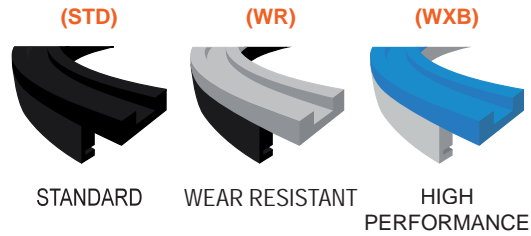
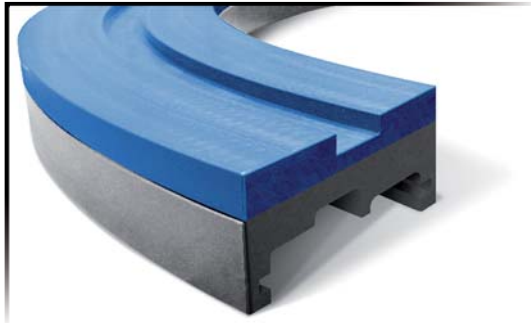

K = 190,5

COD.	*MAT.	R1	A	AG	α	VIAS
CM.0660.01.15.STD	STD	860	107	214	15	1
CM.0660.01.30.STD		860	107	214	30	1
CM.0660.01.45.STD		860	107	214	45	1
CM.0660.01.60.STD		860	107	214	60	1
CM.0660.01.75.STD		860	107	214	75	1
CM.0660.01.90.STD		860	107	214	90	1

\* OTHER MATERIALS  
 WEAR RESISTANT: Code + WR  
 HIGH PERFORMANCE: Code + WXB

MODELO CM.P861 / MODEL CM.P861 / MODÈLE CM.P861 / MODELL CM.P861



882 MBP

**M** SPECIAL UHMW-PE

Segun tabla  
 According to table  
 Selon le tableau  
 Laut Tabelle

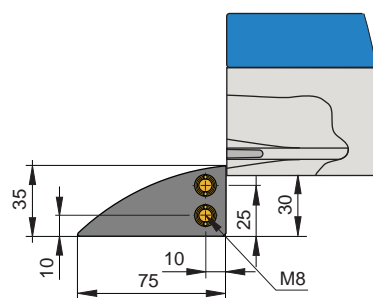
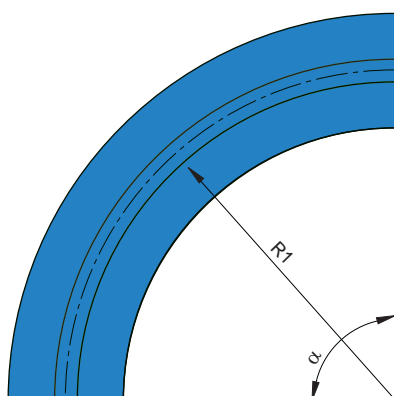
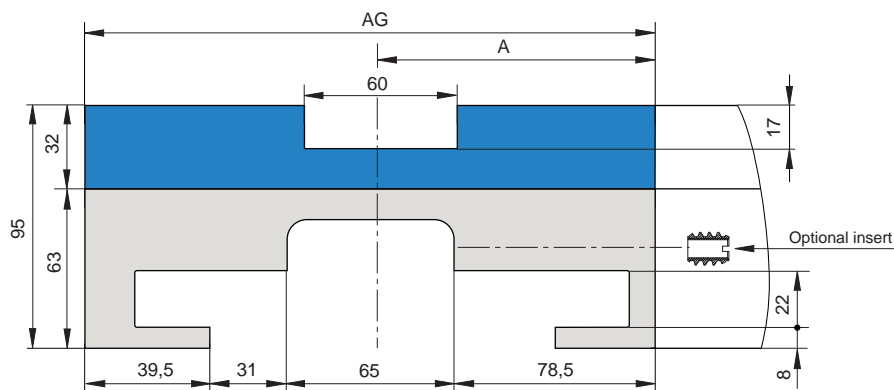
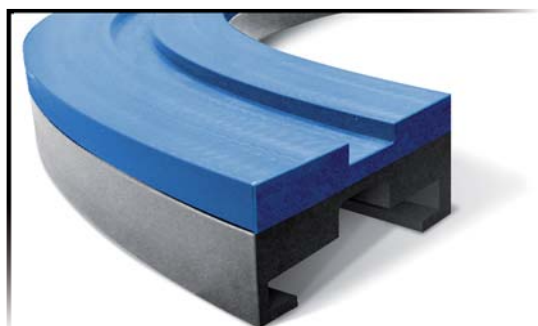

K = 190,5

COD.	*MAT.	R1	A	AG	α	VIAS
CM.P861.01.90.STD	STD	860	107	214	90	1

**\* OTHER MATERIALS**  
 WEAR RESISTANT: Code + WR  
 HIGH PERFORMANCE: Code + WXB

MODELO CM.0910 / MODEL CM.0910 / MODÈLE CM.0910 / MODELL CM.0910



882 M

**M** SPECIAL UHMW-PE

Según tabla  
 According to table  
 Selon le tableau  
 Laut Tabelle

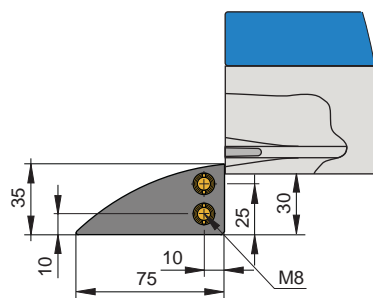
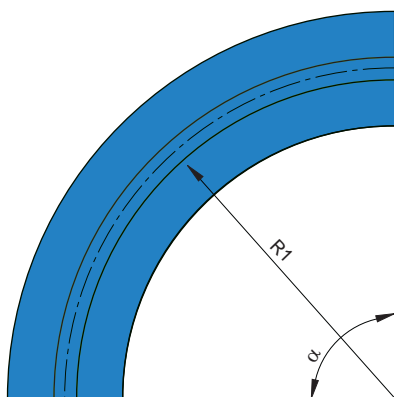
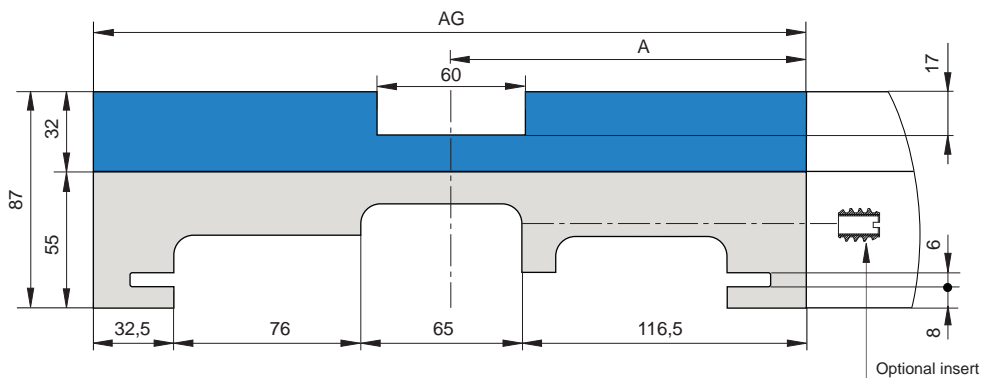
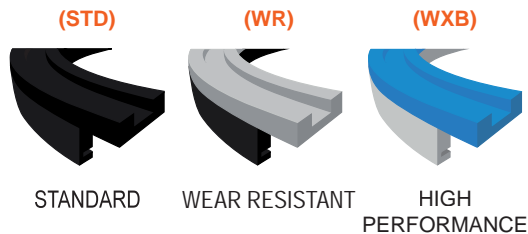
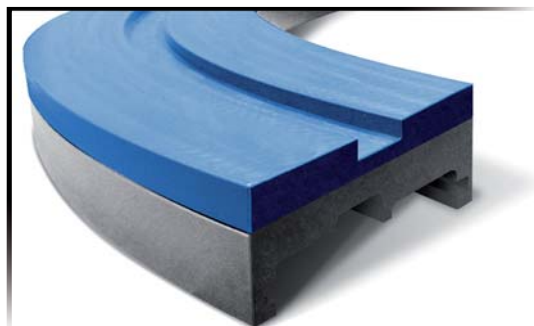

K = 254

COD.	*MAT.	R1	A	AG	α	VIAS
CM.0910.01.15.STD	STD	860	145	290	15	1
CM.0910.01.30.STD		860	145	290	30	1
CM.0910.01.45.STD		860	145	290	45	1
CM.0910.01.60.STD		860	145	290	60	1
CM.0910.01.75.STD		860	145	290	75	1
CM.0910.01.90.STD		860	145	290	90	1

\* OTHER MATERIALS  
 WEAR RESISTANT: Code + WR  
 HIGH PERFORMANCE: Code + WXB

MODELO CM.P910 / MODEL CM.P910 / MODÈLE CM.P910 / MODELL CM.P910

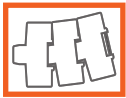

882 MBP

**M** SPECIAL UHMW-PE

Segun tabla  
 According to table  
 Selon le tableau  
 Laut Tabelle

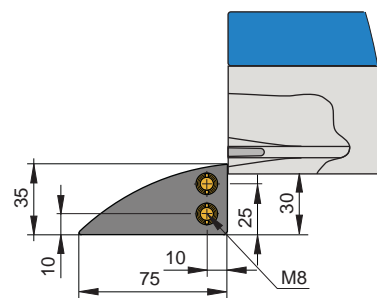
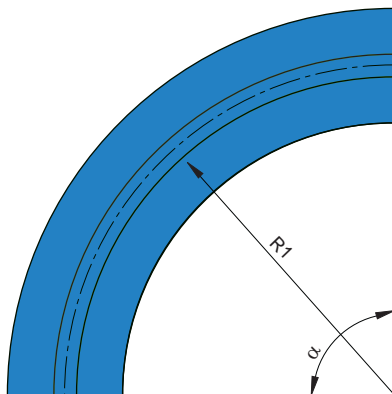
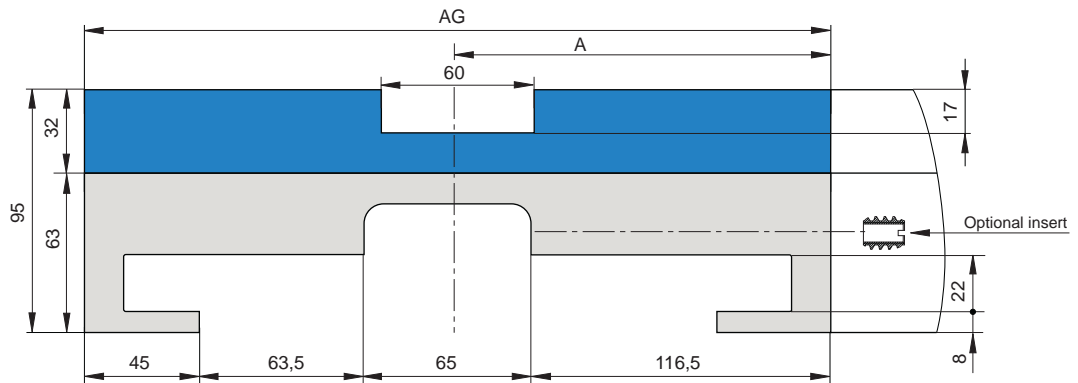
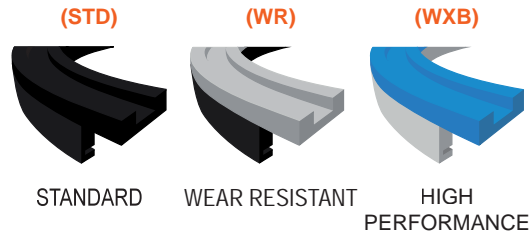
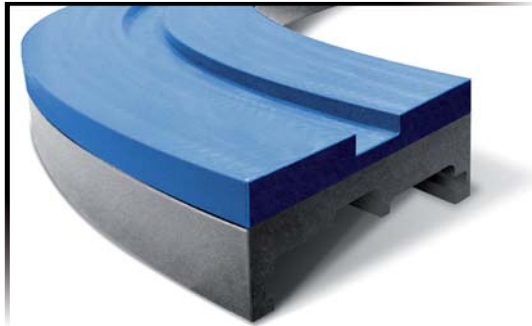

K = 254

COD.	*MAT.	R1	A	AG	α	VIAS
CM.P910.01.15.STD	STD	860	145	290	15	1
CM.P910.01.30.STD		860	145	290	30	1
CM.P910.01.45.STD		860	145	290	45	1
CM.P910.01.60.STD		860	145	290	60	1
CM.P910.01.75.STD		860	145	290	75	1
CM.P910.01.90.STD		860	145	290	90	1

\* OTHER MATERIALS  
 WEAR RESISTANT: Code + WR  
 HIGH PERFORMANCE: Code + WXB

MODELO CM.0960 / MODEL CM.0960 / MODÈLE CM.0960 / MODELL CM.0960

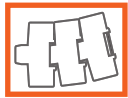

882 M

**M** SPECIAL UHMW-PE

Según tabla  
 According to table  
 Selon le tableau  
 Laut Tabelle

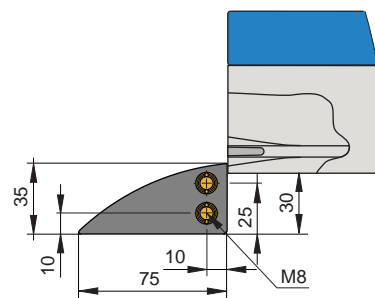
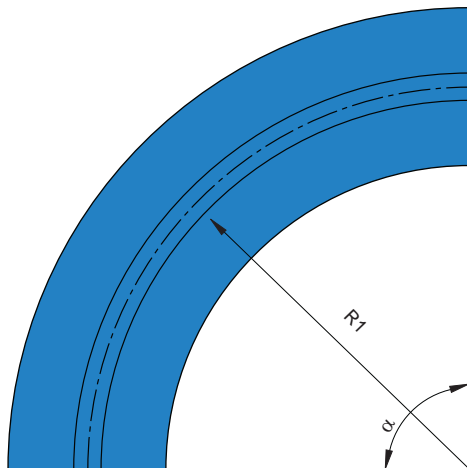
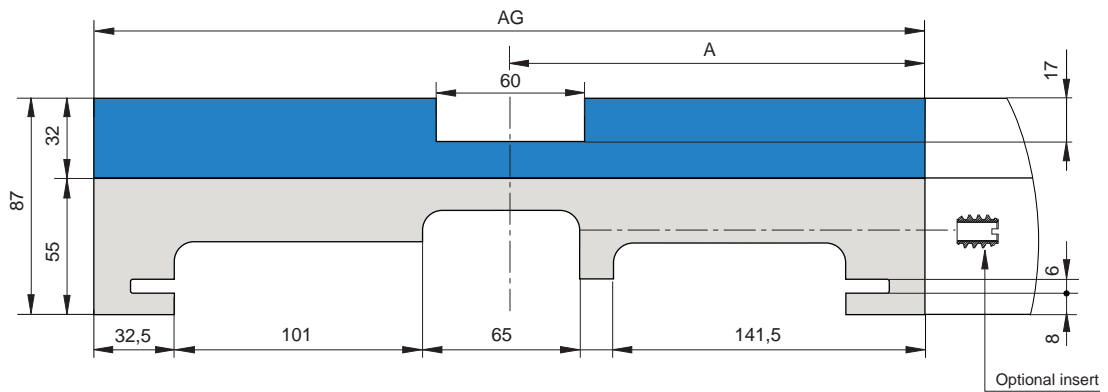
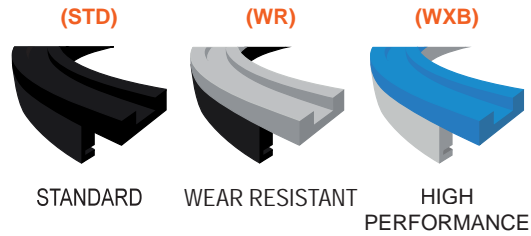
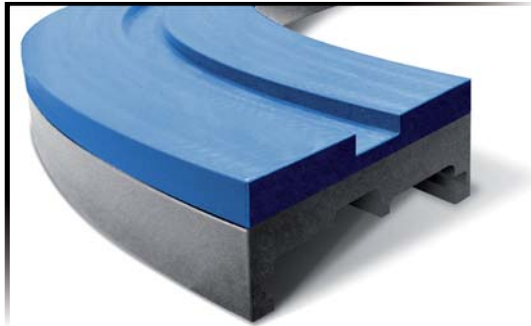

K = 304,8

COD.	*MAT.	R1	A	AG	α	VIAS
CM.0960.01.15.STD	STD	860	170	340	15	1
CM.0960.01.30.STD		860	170	340	30	1
CM.0960.01.45.STD		860	170	340	45	1
CM.0960.01.60.STD		860	170	340	60	1
CM.0960.01.75.STD		860	170	340	75	1
CM.0960.01.90.STD		860	170	340	90	1

\* OTHER MATERIALS  
 WEAR RESISTANT: Code + WR  
 HIGH PERFORMANCE: Code + WXB

MODELO CM.P960 / MODEL CM.P960 / MODÈLE CM.P960 / MODELL CM.P960



882 MBP

**M** SPECIAL UHMW-PE

Segun tabla  
 According to table  
 Selon le tableau  
 Laut Tabelle

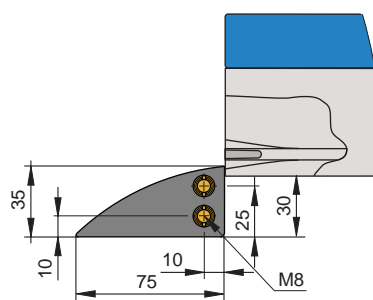
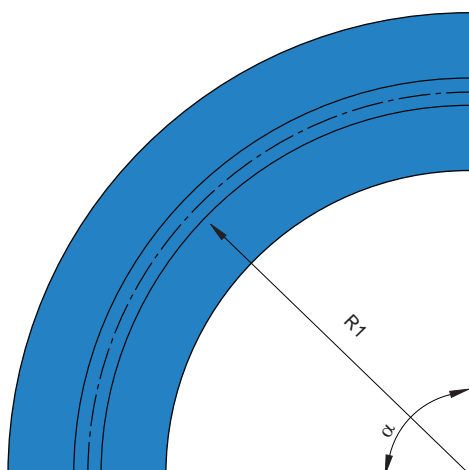
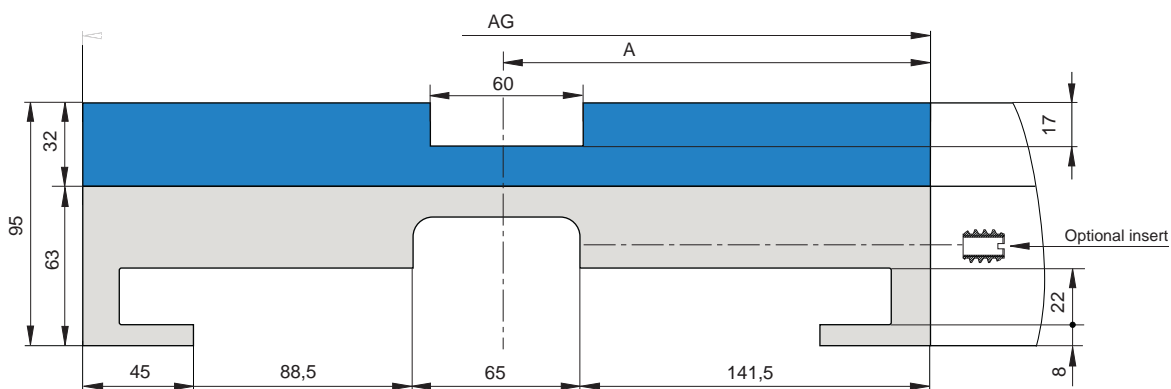
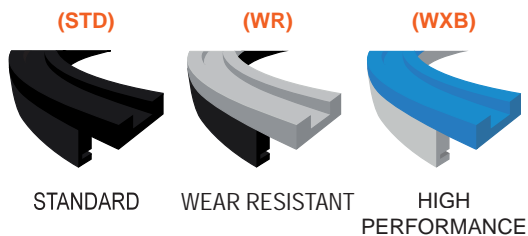

K = 304,8

COD.	*MAT.	R1	A	AG	α	VIAS
CM.P960.01.15.STD	STD	860	170	340	15	1
CM.P960.01.30.STD		860	170	340	30	1
CM.P960.01.45.STD		860	170	340	45	1
CM.P960.01.60.STD		860	170	340	60	1
CM.P960.01.75.STD		860	170	340	75	1
CM.P960.01.90.STD		860	170	340	90	1

\* OTHER MATERIALS  
 WEAR RESISTANT: Code + WR  
 HIGH PERFORMANCE: Code + WXB

# CURVAS MAGNÉTICAS / MAGNETIC CURVES

# COURBES MAGNÉTIQUES / MAGNETISCHE KURVEN

MODELO CM.0430 / MODEL CM.0430 / MODÈLE CM.0430 / MODELL CM.0430

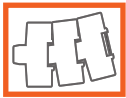

879 M - 880 M - 881 M - 881 MX

**M** SPECIAL UHMW-PE

Según tabla  
 According to table  
 Selon le tableau  
 Laut Tabelle

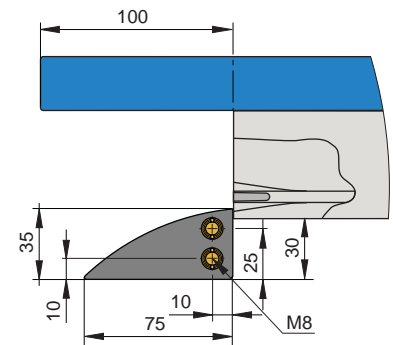
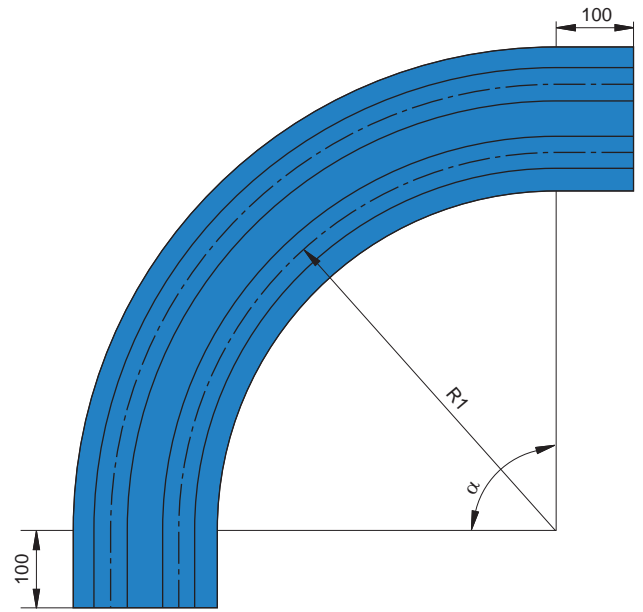
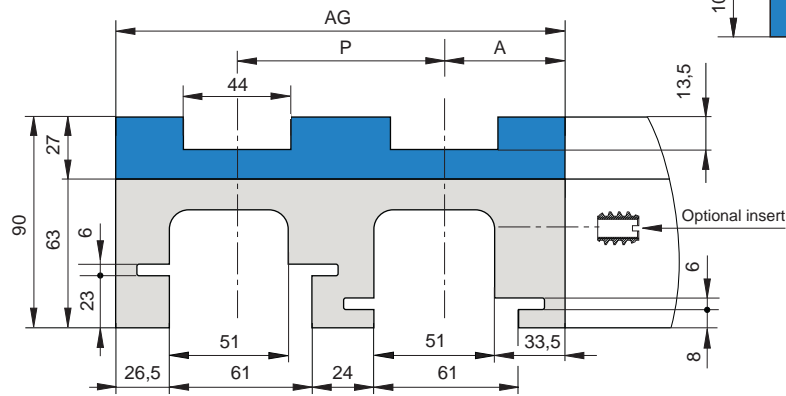
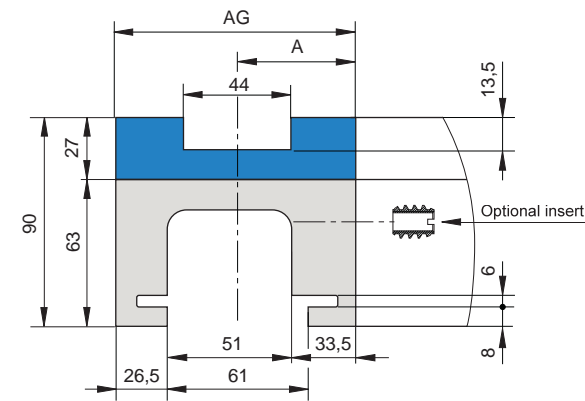
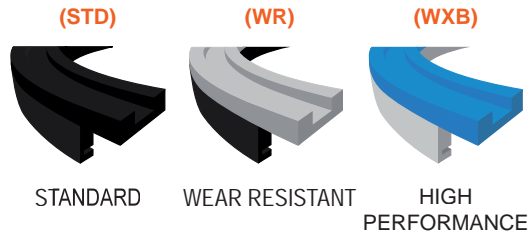
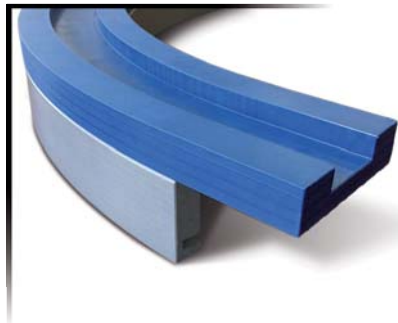

K = 82,5 - K = 83,8

COD.	*MAT.	R1	A	AG	α	VIAS
CM.0430.01.90.STD	STD	1000	55,5	111	90	1
CM.0430.02.90.STD		1000	55,5	196	90	2
CM.0430.03.90.STD		1000	55,5	281	90	3
CM.0430.04.90.STD		1000	55,5	366	90	4
CM.0430.05.90.STD		1000	55,5	451	90	5
CM.0430.06.90.STD		1000	55,5	536	90	6

\* OTHER MATERIALS  
 WEAR RESISTANT: Code + WR  
 HIGH PERFORMANCE: Code + WXB

MODELO CM.0650 / MODEL CM.0650 / MODÈLE CM.0650 / MODELL CM.0650



881 M

**M** SPECIAL UHMW-PE

Segun tabla  
 According to table  
 Selon le tableau  
 Laut Tabelle

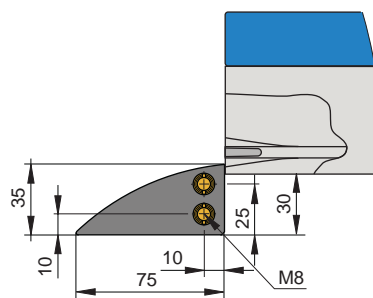
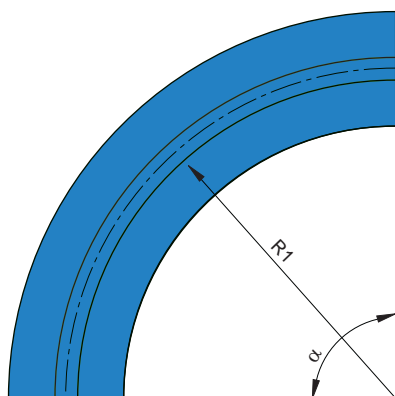
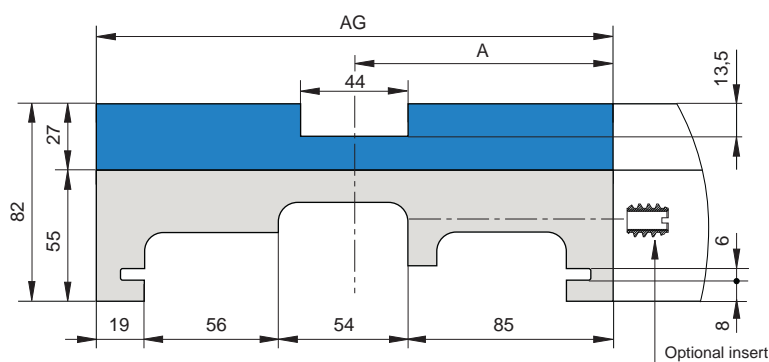
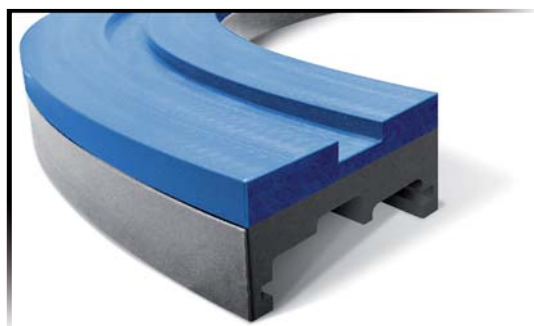

K = 190,5

COD.	*MAT.	R1	A	AG	α	VIAS
CM.0650.01.15.STD	STD	1000	107	214	15	1
CM.0650.01.30.STD		1000	107	214	30	1
CM.0650.01.45.STD		1000	107	214	45	1
CM.0650.01.60.STD		1000	107	214	60	1
CM.0650.01.75.STD		1000	107	214	75	1
CM.0650.01.90.STD		1000	107	214	90	1

\* OTHER MATERIALS  
 WEAR RESISTANT: Code + WR  
 HIGH PERFORMANCE: Code + WXB







The data and information contained in the present catalogue are up-to-dated to the date of the catalogue's printing. Megadyne Spa reserves the right to modify the specifications, performances and other information relating to the belts described in the present catalogue, at any time at its own discretion, without any prior notice. For updating refer to our web site [www.megadynegroup.com](http://www.megadynegroup.com).

Technical specifications, performances and other information provided in the present catalogue are indicative and do not bound Megadyne unless such specifications, performances or other information are expressly agreed in the agreement with the customer.

We also recommend to read carefully the following documents in our web site [www.megadynegroup.com](http://www.megadynegroup.com):

- Megadyne General Conditions of Sale (comprising the warranty)
- Theoretical Belt Life
- Drive Components: Storage, Installation, Maintenance and Troubleshooting Handbook
- Belts standard use condition and temperature.

Copyright Notice: Megadyne Spa copyright. All rights reserved. Megadyne is and shall remain the owner of all rights on drawings, technical specifications and any other information contained in the present catalogue or otherwise communicated by Megadyne Spa to the customer. The customer shall not disclose such information to third parties or use such information for purposes different from the definition of the order to Megadyne Spa, unless upon prior written authorization of Megadyne.



**BELARUS**

**Minsk**  
Phone +375 17 2802486  
Info.by@megadynegroup.com

**BRASIL**

**Sorocaba**  
Phone +55 15 2101 7700  
info.br@megadynegroup.com

**CANADA**

**Edmonton**  
Phone: +1 780 461 4400  
info.ca@megadynegroup.com

**Montreal**

Phone: +1 514 31 2341  
info.ca@megadynegroup.com

**Toronto**

Phone: +1 905 602 4400  
info.ca@megadynegroup.com

**CHINA**

**Beijing**  
Phone +86 10 8150 7478  
info.cn@megadynegroup.com

**Foshan**

Phone +86 757 83815530  
info.cn@megadynegroup.com

**Fujian**

Phone +86 595 8816 0309  
info.cn@megadynegroup.com

**Ningbo\***

Phone +86 574 8650 2886  
info.cn@megadynegroup.com

**Qingdao\***

Phone +86 532 8765 2117  
info.cn@megadynegroup.com

**Shanghai**

Phone +86 21 5447 1473  
info.cn@megadynegroup.com

**Shenyang**

Phone +86 24 2572 3238  
info.cn@megadynegroup.com

**COLOMBIA**

**Cartagena**  
Phone: 011 57 313 501 5397  
info.co@megadynegroup.com

**CZECH REPUBLIC**

**Prague**  
Phone +420 2 8481 7181  
info.cz@megadynegroup.com

**FRANCE**

**Paris**  
Phone +33 1 6079 8200  
info.fr@megadynegroup.com

**St. Jean De Maurienne\***

info.fr@megadynegroup.com

**GERMANY**

**Borchen**  
Phone +49 5251 8735 0  
info.de@megadynegroup.com

**Elchingen\***

info.de@megadynegroup.com

**HUNGARY**

**Budapest**  
Phone +36 23 428 628  
info.hu@megadynegroup.com

**INDIA**

**CHENNAI\***  
Phone +91 98841 81175  
sales@helicord.in

**ITALY**

**Turin\***  
Phone +39 011 926 8052  
info@megadynegroup.com

**Milan\***

Phone +39 039 689 601  
info.it@megadynegroup.com

**Pescara**

Phone +39 085 970 0386  
info@sacif.it

**Venice**

Phone +39 041 929 367  
info.it@megadynegroup.com

**MEXICO**

**Mexico C.P.**  
Phone +52 55 5587 3680  
info.mx@megadynegroup.com

**PERU**

**Lima**  
Phone +51 995 866 561  
info.mx@megadynegroup.com

**POLAND**

**Bydgoszcz\***  
Phone +48 52 348 77 12  
info.pl@megadynegroup.com

**SOUTH AFRICA**

**Johannesburg**  
Phone +27 (0)12 661 1652  
info.za@megadynegroup.com

**Cape Town**

Phone +27 (0)21 9820772  
info.za@megadynegroup.com

**SPAIN**

**Barcelona\***  
Phone +34 93 811 5450  
info.sp@megadynegroup.com

**Cornellà\***

Phone +34 93 377 6453  
info.sp@megadynegroup.com

**SWEDEN**

**Kristianstad**  
Phone +46 10 1309600  
info.se@megadynegroup.com

**THAILAND**

**Bangkok**  
Phone: +66 (0) 27115477  
info.th@megadynegroup.com

**TURKEY**

**Izmir\***  
Phone +90 232 877 07 00  
info.tr@megadynegroup.com

**U.K.**

**Birmingham**  
Phone: +44 1384 215 021  
info.uk@megadynegroup.com

**U.S.A****California**

Phone +1 323 265 8061  
info.us@megadynegroup.com

**Florida**

Phone +1 813 241 4111  
info.us@megadynegroup.com

**Georgia\***

info.us@megadynegroup.com

**Illinois**

Phone: +1630 752 0600  
info.us@megadynegroup.com

**New Jersey Americas HQ**

Phone +1 973 227 4904  
info.us@megadynegroup.com

**New York\***

Phone +1 (888) 755 7450  
info.us@megadynegroup.com

**North Carolina\***

info.us@megadynegroup.com

**Oregon**

Phone +1 888 231 7224  
info.us@megadynegroup.com

**Texas**

Phone +1 972 438 6992  
info.us@megadynegroup.com

**HEADQUARTERS****ITALY Turin**

Via S. Lucia, 114  
10075 Mathi (Torino)  
Phone +39 011 926 8052  
info@megadynegroup.com

[www.megadynegroup.com](http://www.megadynegroup.com)

