

**SIEMENS**

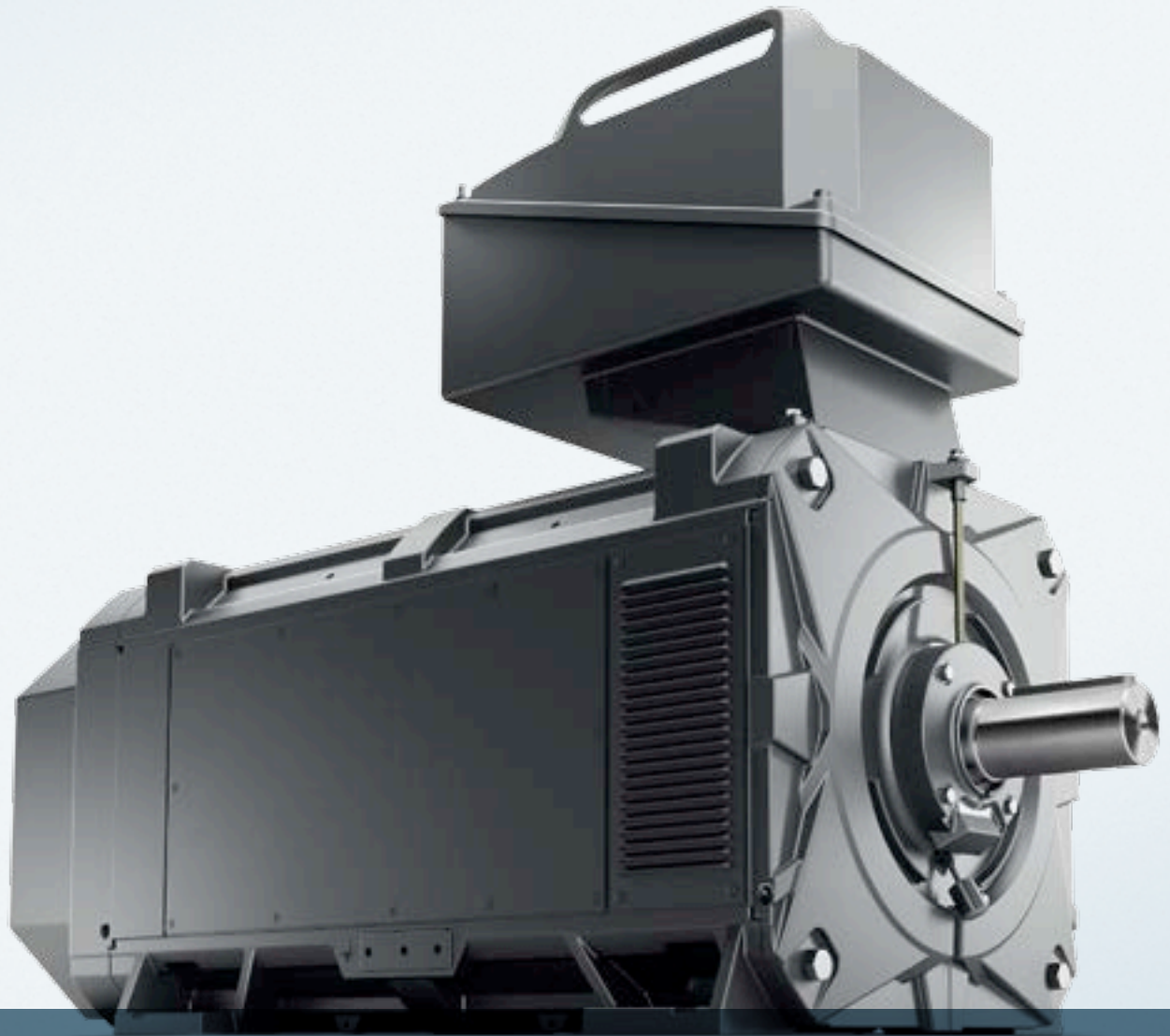













# SIMOTICS FD

Flexible Duty motors – flexible, efficient and powerful

[siemens.com/simotics-fd](https://www.siemens.com/simotics-fd)

Answers for industry.

# The family of SIMOTICS motors is growing

SIMOTICS												
Low-voltage motors for line and converter operation							Motion control motors				DC motors	High-voltage motors
General Purpose SIMOTICS GP	Severe Duty SIMOTICS SD	Explosion protected SIMOTICS XP	Definite Purpose SIMOTICS DP	Flexible Duty SIMOTICS FD	Trans-standard SIMOTICS TN	High Torque SIMOTICS HT	Servo motors SIMOTICS S	Main motors SIMOTICS M	Linear motors SIMOTICS L	Torque motors SIMOTICS T	SIMOTICS DC	SIMOTICS HV
												
IEC: 0.09 ... 45 kW NEMA: 1 ... 20 HP	IEC: 0.75 ... 315 kW NEMA: 1 ... 400 HP	IEC: 0.09 ... 1,000 kW NEMA: 1 ... 400 HP	0.37 ... 481 kW	200 ... 740 kW	200 ... 3,500 kW	150 ... 2,100 kW	0.05 ... 34.2 kW	2.8 ... 1,340 kW	1.29 ... 119.3 kW	1.7 ... 380 kW	30 ... 1,610 kW	200 kW ... 100 MW

## SIMOTICS stands for:

- 125 years of experience in building electric motors
- The most extensive range of motors worldwide
- Optimum solutions in all sectors, regions and power & performance classes
- Innovative motor technologies with the highest quality and reliability
- Highest dynamic performance, precision and efficiency with at the same time an optimum level of compactness
- Integrated into the drive train from the motor side
- A global network of skill sets and worldwide service around-the-clock

The history behind the world's most comprehensive range of motors started about 150 years ago when in 1866, Werner von Siemens developed the dynamo-electric principle. This principle was the platform for the design of high-performance electric motors – creating the basis for the widespread use of electric motors in industry. Since then, motor development has been a core business of the company – and Siemens, with its experience going back far more than a century, is the pacemaker when it comes to innovative motor technology.

Carrying on this long tradition and living up to our claim that we always offer our customers innovative and efficient technology to address increasing requirements, we have extended our family of SIMOTICS motors to include the Flexible Duty SIMOTICS FD motors.

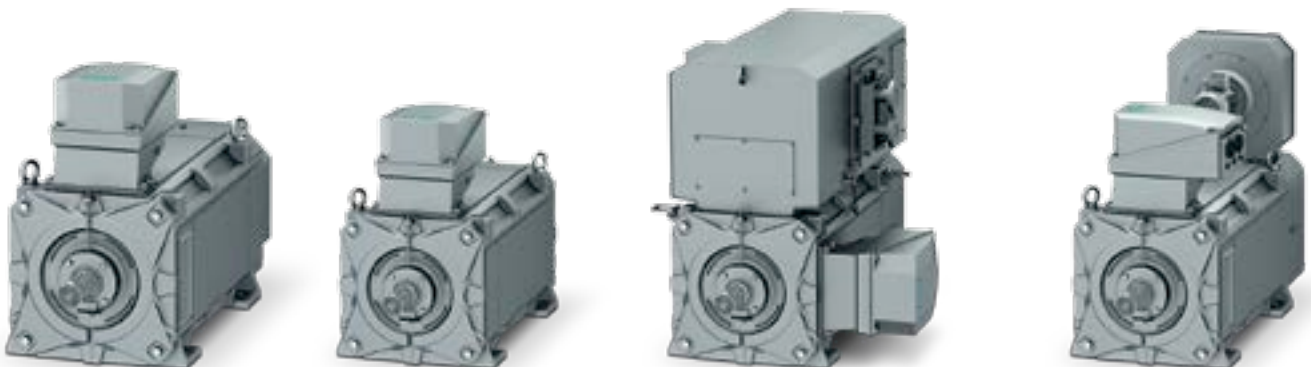

# SIMOTICS FD – more flexibility for powerful motors

A whole range of requirements is placed on state-of-the-art high rating motors: For instance, they should have a high efficiency, be able to be used flexibly, quiet in operation and optimally adapted for drive operation. The series of SIMOTICS FD motors is specifically developed to fulfill all of these requirements. As a result of their flexibility and the wide range of versions, SIMOTICS FD motors are suitable for all sectors of industry.

## Many applications can be addressed

In the power range from 200 kW up to over 1600 kW when fully available, SIMOTICS FD is the basis for a complete, cost-effective system comprised of a motor and drive with a high power density. Using a wide range of versions, the motors can be flexibly and efficiently used in the widest range of applications and sectors. The motors are rugged and durable as a result of their cast iron frame. The water-cooled motors allow an extensive range of other applications to be addressed.

## Flexible modular system

Our Flexible Duty SIMOTICS FD motors utilize a leading-edge modular system in order to be able to provide the optimum motor to address various of requirements. They are available in the widest range of cooling types. Explosion-protected Ex n and Ex t versions (Zones 2 and 22) are also included in the portfolio. The combination and optimum coordination to operate with our SINAMICS drives means that SIMOTICS FD motors are especially cost-effective and powerful.

## Extensive range of cooling methods

With SIMOTICS FD, you simply adapt the cooling method to address your particular requirements. You can select between open and enclosed versions – with self ventilation or forced ventilation. Further, there are also water-cooled versions with water jacket cooling or air-water heat exchangers.

## Rugged and easy to connect

The following characteristic features make SIMOTICS FD a great choice when it comes to the original equipping and retrofit:

- High power density but with low envelope dimensions
- High overload capability
- Low noise level
- Flexible terminal box position
- User friendly terminal box with diagonal split
- Various encoder systems
- Wide range of options with various sector packages
- Country- or sector-specific approvals

Replacement is convenient as SIMOTICS FD motors have the identical mounting dimensions as the previous series.

## Cost-effective combination: SIMOTICS and SINAMICS

The combination of SIMOTICS FD and SINAMICS G120P, G130, G150, S120 / S120CM or S150 low-voltage frequency converter is especially cost-effective as the motor and drive are precisely coordinated and harmonized with one another. The rated motor currents are adapted to match the frequency converter output currents and the motor is designed for the rated frequency converter pulse frequency. This means that the drive is not overdimensioned, and an optimum voltage utilization is ensured with low noise emission when operated from SINAMICS G and SINAMICS S drives.

## Straightforward selection

By assigning the motor to the preferred SINAMICS drive, the optimum motor-drive combination can be simply and transparently selected. Further, in the SIMOTICS FD Catalog, you can also find data on the sound pressure level when the motors are fed from SINAMICS frequency converters.

# SIMOTICS FD

## Enclosed air-cooled

**Self-ventilated SIMOTICS FD: Higher efficiencies, lower energy usage, lower lifecycle costs**

SIMOTICS FD offers a whole range of concrete advantages. A rugged frame and bearing shields manufactured out of cast iron, for instance. You even have the choice between various efficiency levels for lower energy consumption.

Selected versions are available as Preferred Line – or with especially short delivery times, as Express Line.



**Force-ventilated SIMOTICS FD: Low noise or with increased power**

SIMOTICS FD with forced ventilation is a great choice when it involves applications with a constant load torque. Various units for forced ventilation are available, which facilitate low-noise operation or increased power.

Different mounting configurations for the forced ventilation provide you with a higher degree of flexibility when planning your system. Configurations exist for either axial or radial mounting of the ventilation units.

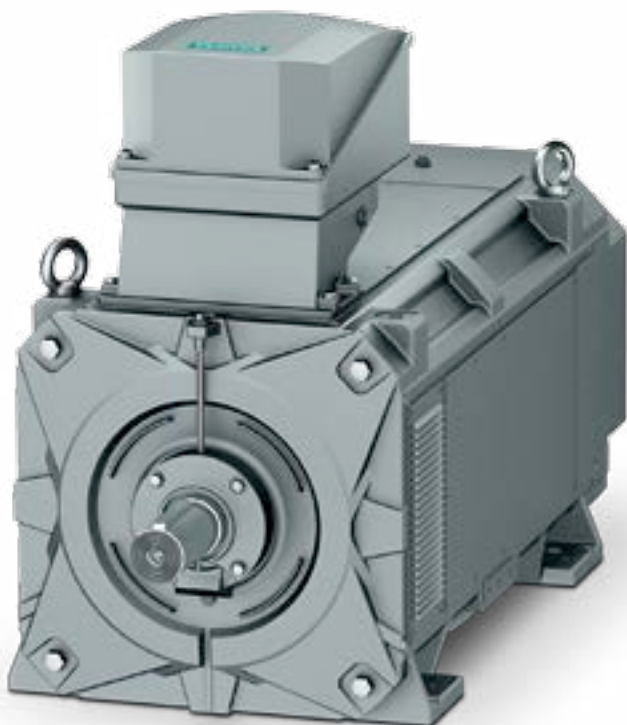

Self-ventilated SIMOTICS FD – ideal for driving pumps, fans and compressors with a square-law characteristic

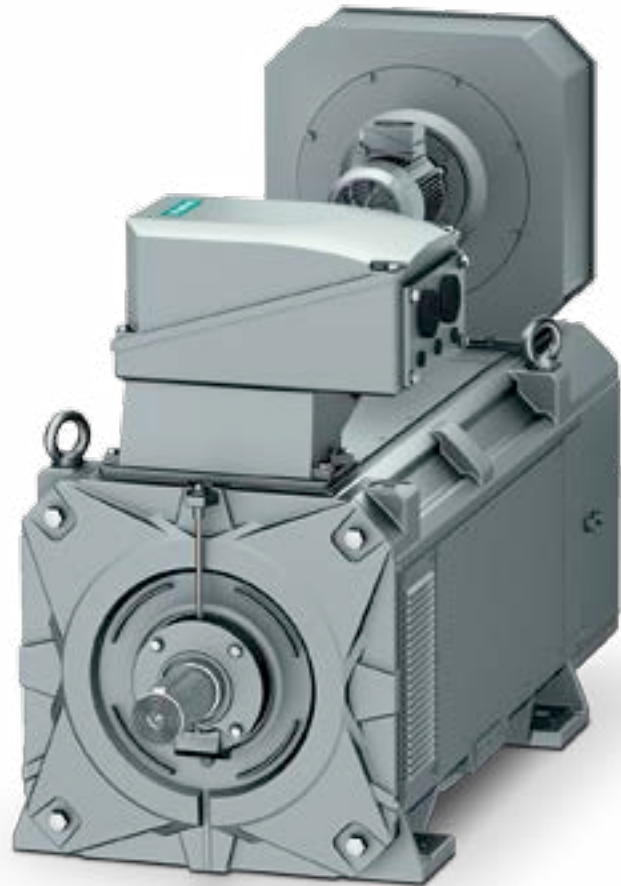

Force-ventilated SIMOTICS FD – low noise or with increased power for applications with a constant load torque, e.g. conveyor belts

Technical data	
Power range	200 to 530 kW (up to 1150 kW in preparation)
Shaft height	315, 355 (up to 450 in preparation)
Version	Motor optimized for operation with SINAMICS drives
Line supply voltages	50 Hz line supplies: 400/500/690 V; 60 Hz line supplies: 460/575 V (additional voltages on request)
Degree of protection	Standard: IP55, optional: IP56, non-heavy sea or IP65
Sound-pressure level under no-load conditions on a SINAMICS drive	Low noise standard version: 79 dB(A) increased power version: 85 dB(A)
Cooling method	Self ventilated (IC411); force ventilated (IC416)
Temperature classes	180 (H) - 155 (F); optional: 180 (H) - 130 (B)
Efficiency classes	<ul style="list-style-type: none"> <li>Efficiency corresponds to IE2 efficiencies up to 375 kW for rated speeds 1800, 1500, 1200 and 1000</li> <li>Increased efficiency corresponds to IE3 efficiencies up to 375 kW for rated speeds 1800, 1500, 1200 and 1000</li> </ul>
Primary load characteristic	Self-ventilated motors, $M \sim n^2$ ; force-ventilated motors, $M = \text{const}$

# SIMOTICS FD

## Water-cooled

**Wide range of power ratings, coolant flexibility:**  
SIMOTICS FD with water jacket cooling or air-water heat exchanger

As a result of the water jacket cooling, which can either be copper or optionally stainless steel, SIMOTICS FD can be optimally adapted to address specific customer requirements and the prevailing water quality available. Further, the heat can be specifically dissipated and used as process heat.

The cooling water is connected axially at the NDE. When requested, the cooling pipe connections can also be fed out to the top or to the side. As an alternative to the water jacket cooling, you also have the option of mounting an air-water heat exchanger on the motor. This allows you to adapt the cooling power and the cooling method to your specific site conditions.



**SIMOTICS FD offers a seamless and integrated range of products for your sector**

The water-cooled motors are versatile, and for instance, can be used in the plastics, marine, paper or oil and gas sectors. The comprehensive range of power ratings and the flexibility when selecting the coolant mean that the motor can be optimally adapted to the particular application.



SIMOTICS FD with water jacket cooling

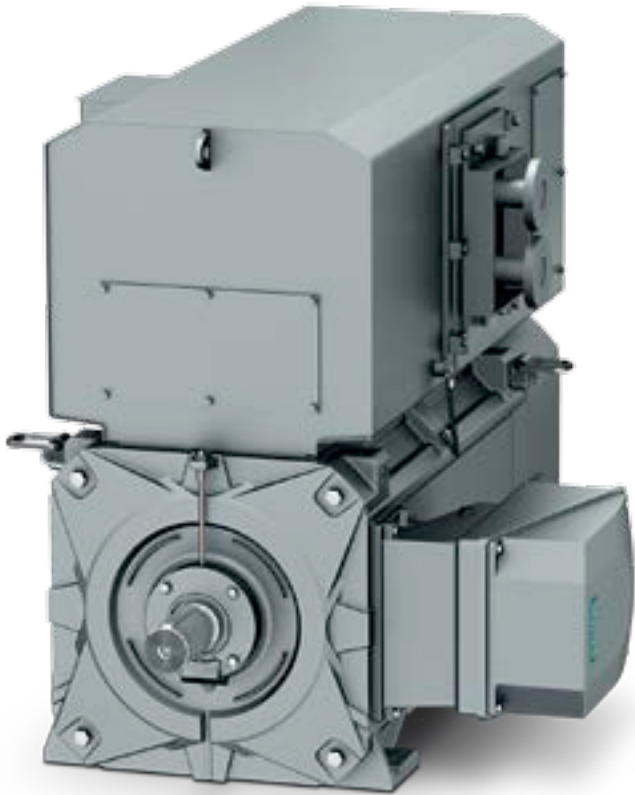

SIMOTICS FD with air-water heat exchanger

Technical data	Water jacket cooling	Air-water heat exchanger
Power range	200 to 650 kW (up to 1.325 kW in preparation)	200 to 670 kW (up to 1.500 kW in preparation)
Shaft height	315, 355 (up to 450 in preparation)	
Version	Motor optimized for operation with SINAMICS drives or motor for line operation	Motor optimized for operation with SINAMICS drives
Line supply voltages	50 Hz line supplies: 400 V, 500/690 V; 60 Hz line supplies: 460 V, 575 V (other voltages on request)	
Degree of protection	Standard: IP55, optional: IP56 non-heavy sea, IP65	
Sound pressure level	78 dB(A)	79 dB(A)
Cooling method	IC71W	IC86W
Temperature classes	Frequency converter operation 180 (H) – 155 (F) optional: 180 (H) – 130 (B) Line operation 180 (H) – 130 (B) optional: 180 (H) – 155 (F)	180 (H) - 155 (F); optional: 180 (H) - 130 (B)
Efficiency classes	Line operation: IE2 and IE3 up to 375 kW	
Primary load characteristic	M ~ n <sup>2</sup> ; M = const,	

# SIMOTICS FD

Open air-cooled

Flexible plant and system planning:  
SIMOTICS FD with open-circuit ventilation

The open version of SIMOTICS FD motors is used where a high power density with low envelope dimensions and weight is demanded. The motors are especially suitable for systems where an IP23 degree of protection is sufficient. The extensive range of SIMOTICS FD motors ensures that you can always find the optimum cost-effective solution for your particular application – whether planning your plant or system or when it comes to a retrofit.

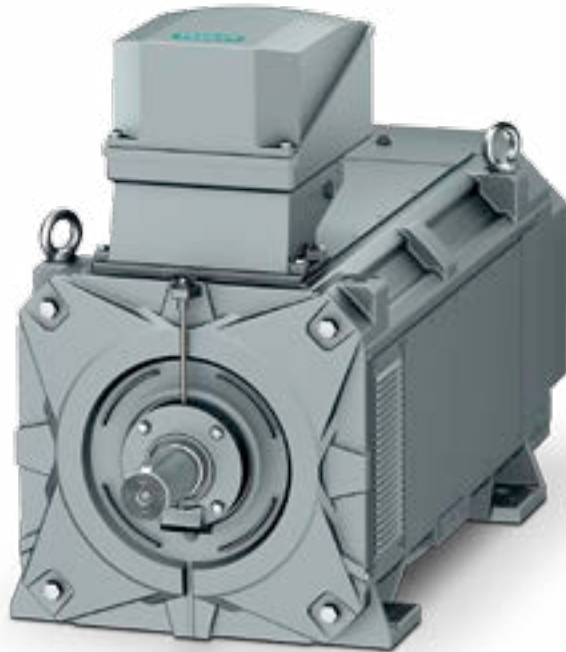

Open air-cooled SIMOTICS FD motors with self ventilation are used for pumps, fans and compressors with a square-law characteristic.





**Versatile and adaptable:  
SIMOTICS FD with forced ventilation**

Also for the open versions of SIMOTICS FD motors, there are various configurations for forced ventilation, either for low noise or for increased power. As with the enclosed version, the external fan unit can be either axially or radially mounted. And naturally, here you can choose between various radially mounted versions.

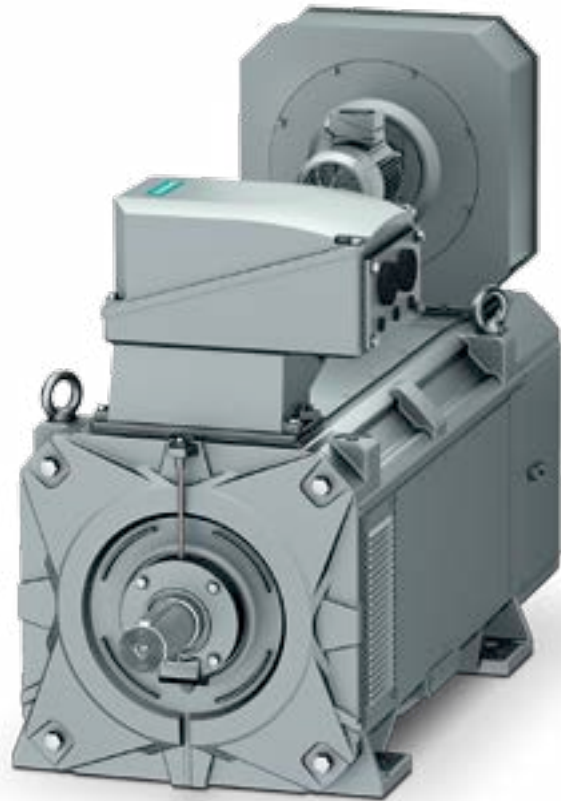

Open air-cooled SIMOTICS FD motors with forced ventilation - low noise or with increased power for applications with a constant load torque, e.g. cranes

Technical data	
Power range	200 to 740 kW (up to 1.690 kW in preparation)
Shaft height	315, 355 (up to 450 in preparation)
Version	Motor optimized for operation with SINAMICS drives
Line supply voltages	50 Hz line supplies: 400/500/690 V; 60 Hz line supplies: 460/575 V (additional voltages on request)
Degree of protection	IP23
Sound-pressure level under no-load conditions on a SINAMICS drive	Low noise standard version: 79 dB(A) increased power version: 85 dB(A)
Cooling method	Self ventilated, open-circuit ventilated (IC01) or force ventilated, open-circuit ventilated (IC06)
Temperature classes	180 (H) - 155 (F); optional: 180 (H) - 130 (B)
Primary load characteristic	Self-ventilated motors, $M \sim n^2$ ; force-ventilated motors, $M = \text{const}$

# Perfectly coordinated with one another: SIMOTICS FD and...

If components of a system can be perfectly coordinated and harmonized with one another, then of course, this must have a positive impact on the overall system. We have placed special emphasis on this coordination for operating SIMOTICS FD motors with SINAMICS G120P, G130, G150, S120, S120 CM and S150 frequency converters.

SIMOTICS FD was specifically optimized for operation with SINAMICS drives. For instance, the rated motor currents have been adapted to the frequency converter output currents, and the motors to the rated pulse frequencies of the frequency converter. The voltage is optimally utilized when they are fed from SINAMICS G and S drives. The low noise levels when operating SIMOTICS FD motors with SINAMICS drives is the result of this optimum coordination.

#### Advantages, that make decisions quite easy:

- Especially cost-effective overall system comprising motor and SINAMICS drive, without having to overdimension the frequency converter
- Low losses due to operation at the optimum operating point
- Quiet
- Simple system selection

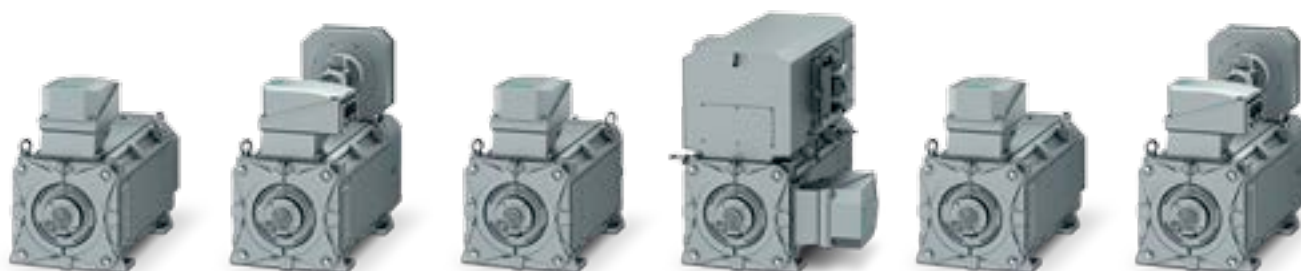

## SIMOTICS FD motors

	Enclosed air-cooled		Water-cooled		Open air-cooled	
	with self ventilation	with forced ventilation	with water jacket cooling	with heat exchanger	with self ventilation	with forced ventilation
Operation with	Frequency converter	Frequency converter	Line/Frequency converter	Frequency converter	Frequency converter	Frequency converter
Cooling method	IC411	IC416	IC71W	IC86W	IC01	IC06
Standard degree of protection	IP55	IP55	IP55	IP55	IP23	IP23

# ... SINAMICS drives

SINAMICS is the Siemens family of drives for industrial machine and plant construction. The SINAMICS family has an optimum version to address almost any application. As a consequence, SINAMICS frequency converters can provide a solution for each and every drive task. In conjunction with SIMOTICS FD motors, Siemens is providing especially high-performance and cost-effective systems.

**SINAMICS G** is designed for standard applications with induction motors.

**SINAMICS S** can be used for demanding drive applications with induction and synchronous motors.

**SINAMICS DCM** is the DC drive of the SINAMICS family.

The following AC low-voltage drives are available for the new SIMOTICS FD motor series:

- SINAMICS G120P – the specialist for pumps, fans and compressors
- SINAMICS G130 and SINAMICS G150 – the universal drive solution for high-rating single-motor drives
- SINAMICS S120, SINAMICS S120 Cabinet Modules – the flexible, modular drive system for demanding drive applications
- SINAMICS S150 – the drive solution for demanding high rating, single-motor drives



## SINAMICS drives

	SINAMICS G			SINAMICS S	
	G120P	G130	G150	S150	S120
	Chassis/Cabinet	Chassis	Cabinet	Cabinet	Chassis/Cabinet Modules
Power range	110 to 400 kW	75 to 800 kW	75 to 2.700 kW	75 to 1.200 kW	1,6 to 4.500 kW
Line supply voltage	380 to 480 V	Low voltage 380 bis 690 V		Low voltage 380 to 690 V	
Cooling method	Air-cooled			Air-cooled	Air-cooled/Liquid-cooled

There's more to it

[www.siemens.com/ids](http://www.siemens.com/ids)

Discover in detail how  
Integrated Drive Systems  
boost your competitive  
edge and improve  
your time to profit.

Integrated  
Drive Systems  
to go: Visit our  
mobile site!



Follow us on:

[www.twitter.com/siemensindustry](https://www.twitter.com/siemensindustry)

[www.youtube.com/siemens](https://www.youtube.com/siemens)

Siemens AG  
Industry Sector  
Large Drives  
P.O. Box 47 43  
90025 NUREMBERG  
Germany

Subject to change without prior notice 04/13  
Order-No.: E20001-A20-P531-V1-7600  
DISPO 21503  
WÜ/50334 GD.LD.XX.LDNM.52.3.04 WS  
11132.0  
Printed in Germany  
© Siemens AG 2013

The information provided in this brochure contains merely general descriptions or characteristics of performance which in case of actual use do not always apply as described or which may change as a result of further development of the products. An obligation to provide the respective characteristics shall only exist if expressly agreed in the terms of contract.

All product designations may be trademarks or product names of Siemens AG or supplier companies whose use by third parties for their own purposes could violate the rights of the owners.